

Retro Elf Plus

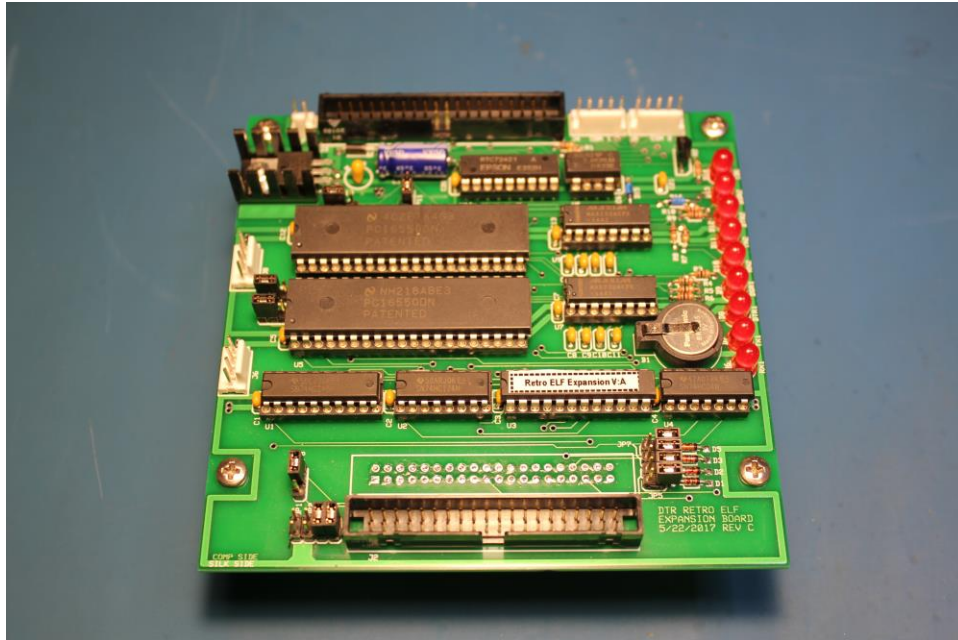

Retro Elf Expansion Board Rev C

Copyright © 2016, 2017 by D.T.Runkle
Website at www.astrorat.com

Permission is granted to copy, distribute and/or modify this document under the terms of the GNU Free Documentation License, Version 1.1 published by the Free Software Foundation. A copy of this license may be obtained from <http://www.gnu.org/licenses/fdl.txt>.

1 – About the expansion board

The expansion board increase the number of features available to the Retro Elf Plus system. The use of low power CMOS components helps keep the board's power needs to a minimum. A simple on board positive 5 volt DC voltage regulator is implemented to power the expansion board. This regulator can supply 5 volts at up to half an amp when an 8-12 volts DC input is supplied to the board. A protection diode is used to help protect against accidental reversal of input power. Four jumpers are provided to select how the Retro Elf Plus system will be powered. The complete system (CPU, front panel, slow clock board and expansion board) can be powered by ether the CPU's or expansion board's on board voltage regulations. In some cases you may need to power the CPU, front panel and slow clock board separately from the expansion board. These four jumpers allow the flexibility to setup the systems power needs for your specific implementation.

Two COM ports are implemented using 16550, high speed, serial UART chips. Each COM port is interfaced using a MAX232A integrated circuit to create standard RS232 signal levels on the serial lines. This allows for easy connection to most terminal or computer serial ports supporting RS232 signaling. Both COM ports support hardware handshaking to allow for the fast transferring of serial data. Two jumpers for each of the COM port channels are used to select if DTR/DSR or RTS/CTS pairs signaling will used to support handshaking. Four diagnostics LEDs are provided on each COM port channel to indicate the status of TX, RX and handshake lines.

A 40-pin header is configured to conform to most of the standard ATA-3 specifications. This supports pretty much any ATA device that conform to:

1. Support for 8-bit transfer mode.
2. Support for logical block addressing (LBA) mode.

This connector is used to attach external devices like IDE disk drives or many versions of Compact Flash cards.

A simple four pin header is provided to support the addition streaming of external interfaces that support the use of an audio tape recorder or streaming floppy to save programs.

Real-Time-Clock or RTC support is provided using an Epson RTC72421 module. This RTC module provides highly accurate time-keeping and supports time and date for hours, minutes, seconds, month, day, year and day-of-week. An on board backup battery provides continuous operation of the RTC even when no power is being supplied to the Retro Elf Plus. The RTC can also be programmed to supply fixed-period interrupts to the Retro Elf Plus system.

2- Assembly

Before you begin, some helpful hints

Follow the instructions carefully and read the entire step before you perform the operation. Solder a part or group of parts only when you are instructed to do so.

Each circuit part in an electronic kit has its own component number (R2, C4, etc.). Use these numbers when you want to identify that same part in the various sections of the Manual. These numbers, which are especially useful if a part has to be replaced, appear:

- In the Parts List
- At the beginning of each step where a component is installed
- In the schematic

SAFETY WARNING: *Safety glasses are recommended. Avoid eye injury when you cut off excess lead lengths. Hold the leads so they cannot fly toward your eyes.*

Soldering

Soldering is one of the most important operations you will perform while assembling your kit. A good solder connection will form an electrical connection between two parts, such as a component lead and a circuit board foil. A bad solder connection could prevent an otherwise well-assembled kit from operating properly.

It is easy to make a good solder connection if you follow a few simple rules:

- Use the right type of soldering iron. If available, a temperature controlled soldering iron is recommended. Otherwise use a 25 to 40-watt pencil soldering iron. In either case use a 1/8" or 3/16" chisel or pyramid tip for best results.
- Keep the soldering iron tip clean. Wipe it often on a wet sponge or cloth; then apply solder to the tip to give the entire tip a wet look. This process is called tinning, and it will protect the tip and enable you to make good connections. When solder tends to "ball" or does not stick to the tip, the tip needs to be cleaned and retinned.
- Use only a high quality rosin-core, 62/36/2 silver-bearing solder with a 0.020 or 0.015 inch diameter.
- A good solder connection is made when you heat the component lead and the foil on the circuit board at the same time. This will allow the solder to flow evenly onto the lead and foil. The solder will then make a good electrical connection between the lead and the foil.

Board Assembly

Refer to the silk screen on the printed circuit board or the Board Layout in Appendix C for parts locations on the board.

Install the ten 1/8 watt resistors at the following locations.

- () R1: 1K ohm, 1/8-watt, 5% (brown-black-red)
- () R2: 470 ohm, 1/8-watt, 5% (yellow-violet-brown)
- () R3: 1K ohm, 1/8-watt, 5% (brown-black-red)

Retro Elf Plus

- () R4: 1K ohm, 1/8-watt, 5% (brown-black-red)
- () R5: 1K ohm, 1/8-watt, 5% (brown-black-red)
- () R6: 1K ohm, 1/8-watt, 5% (brown-black-red)
- () Solder the leads to the foil and cut off the excess lead lengths
- () R7: 1K ohm, 1/8-watt, 5% (brown-black-red)
- () R8: 1K ohm, 1/8-watt, 5% (brown-black-red)
- () R9: 1K ohm, 1/8-watt, 5% (brown-black-red)
- () R10: 1K ohm, 1/8-watt, 5% (brown-black-red)
- () R11: 4.7K ohm, 1/8-watt, 5% (yellow-violet-Red)
- () R12: 4.7K ohm, 1/8-watt, 5% (yellow-violet-Red)
- () Solder the leads to the foil and cut off the excess lead lengths

NOTE: *The next seven diodes are polarized and need to be installed with the banded end matching the outline on the PC board or the board layout. The lead on the banded in should be inserted into the square hole on the PC board.*

- () D1: Orange colored glass diode labeled 1N4148
- () D2: Orange colored glass diode labeled 1N4148
- () D3: Orange colored glass diode labeled 1N4148
- () D4: Black diode labeled 1N4001
- () D5: Orange colored glass diode labeled 1N4148
- () D15: Blue colored glass schottky diode labeled BAT46
- () D16: Blue colored glass schottky diode labeled BAT46
- () Solder the leads to the foil and cut off the excess lead lengths.

Install the nineteen capacitors at the following locations.

- () C1: 0.1uF ceramic
- () C2: 0.1uF ceramic
- () C3: 0.1uF ceramic
- () C4: 0.1uF ceramic
- () C5: 0.1uF ceramic
- () Solder the leads to the foil and cut off the excess lead lengths.

Retro Elf Plus

- () C7: 0.1uF ceramic
- () C8: 0.1uF ceramic
- () C9: 0.1uF ceramic
- () C10: 0.1uF ceramic
- () C11: 0.1uF ceramic
- () Solder the leads to the foil and cut off the excess lead lengths.
- () C13: 0.1uF ceramic
- () C14: 0.1uF ceramic
- () C15: 0.1uF ceramic
- () C16: 0.1uF ceramic
- () C17: 0.1uF ceramic
- () Solder the leads to the foil and cut off the excess lead lengths.
- () C6: 0.1uF ceramic
- () C12: 0.1uF ceramic
- () C20: 0.1uF ceramic
- () C21: 0.1uF ceramic
- () Solder the leads to the foil and cut off the excess lead lengths.

NOTE: 8-pin, 14-pin, 16-pin, 18-pin, 20-pin, narrow 24-pin and 40-pin IC (integrated circuit) sockets are used in this kit. Make sure all pins are straight. Carefully insert the socket pins in to the circuit board holes. Make sure that the index notch on the IC socket is on the same end as pin one (a square pad indicates pin 1) of that IC's location. All sockets are placed on the component side and solder on the solder side of the board. Start by soldering only a single pin to the board. Verify that the socket is aligned and tight against the component side of the board. If not carefully reheat the pin and reposition the IC socket as needed. Once the IC socket is correctly placed, solder the remaining pins.

- () U1 Install a 20-pin IC socket at the following location
- () U2 Install a 16-pin IC socket at the following location
- () U3 Install a narrow 24-pin IC socket at the following location
- () U4 Install a 14-pin IC socket at the following location
- () U5 Install a 40-pin IC socket at the following location
- () U6 Install a 8-pin IC socket at the following location
- () U7 Install a 16-pin IC socket at the following location

Retro Elf Plus

- () U8 Install a 40-pin IC socket at the following location
- () U9 Install a 16-pin IC socket at the following location
- () U11 Install a 18-pin IC socket at the following location

NOTE: The next two capacitors are polarized and have positive and negative leads. Make sure that the positive lead is inserted into the hold marked + (the square hole) on the board.

- () C18: 220uF polarized aluminum electrolytic capacitor.
- () C19: 1.2uF polarized tantalum capacitor.

NOTE: Installing the LEDs, position the flat side as shown to match the outline on the board. Note that the short LED lead is in the square hole on the board. Hold the LEDs tight to the board and solder the leads to the foil and cut off the excess lead lengths.

- () D6: Red LED
- () D7: Red LED
- () D8: Red LED
- () D9: Red LED
- () D10: Red LED
- () D11: Red LED
- () D12: Red LED
- () D13: Red LED
- () D14: Red LED

() Q1: Align the 2N3906 PNP transistor to the silk screen on the board or board layout. Insert each of the three pins in to their respective holes and carefully push the part to about 0.1 inches (3mm) above the board. Bend the leads slightly on the back to hold the part in place.

() Solder the leads to the foil and cut off the excess lead lengths.

Note: When installing the next two 40-pin headers, make sure to install the 40-pin header so that pin 1 is in the hole with the square pad on the board. Solder only one pin then verify that the header is align and tight to the board and pin 1 is in the correct hole. Then solder the remaining pins.

Note: J1 will be installed in a later step.

- () J2: Install a 40-pin header
- () J3: Install a 40-pin header
- () J4: 5-pin header. Match the silk screen or board layout and solder.
- () J5: 5-pin header. Match the silk screen or board layout and solder.

Retro Elf Plus

- () J6: 4-pin header. Match the silk screen or board layout and solder.
- () J7: 2-pin header. Match the silk screen or board layout and solder.
- () J8: 4-pin header. Match the silk screen or board layout and solder.
- () JP1: 2-pin jumper header. Match the silk screen or board layout and solder.
- () JP2: 2-pin jumper header. Match the silk screen or board layout and solder.
- () JP3: 2-pin jumper header. Match the silk screen or board layout and solder.
- () JP4: 2-pin jumper header. Match the silk screen or board layout and solder.
- () JP5: 2-pin jumper header. Match the silk screen or board layout and solder.
- () JP6: 2-pin jumper header. Match the silk screen or board layout and solder.
- () JP7: 2-pin jumper header. Match the silk screen or board layout and solder.
- () JP8: 3-pin jumper header. Match the silk screen or board layout and solder.
- () JP9: 3-pin jumper header. Match the silk screen or board layout and solder.
- () JP10: 3-pin jumper header. Match the silk screen or board layout and solder.
- () JP11: 3-pin jumper header. Match the silk screen or board layout and solder.
- () JP12: 3-pin jumper header. Match the silk screen or board layout and solder.
- () JP13: 2-pin jumper header. Match the silk screen or board layout and solder.
- () B1: 12mm battery holder. Match the silk screen or board layout and solder. Do not install the battery at this time.
- () U10: Locate the following four parts used to assemble the 7805 voltage regulator to the board:
 - Phillips machine screw, M3 x 8mm
 - Hex Nut, M3
 - TO-220 heatsink
 - IC, 7805 5 volt regulator in a TO-220 case
- () The three leads on the 7805 need to be pre-bent before installation. Notice that the leads on the 7805 are wider where they exit the black body of the 7805 and then narrow down. Where the transition from wide to narrow occurs, bend the three leads down towards the metal heat sink side of the 7805 to an angle of 90 degrees. Temporarily set the 7805 aside until required.
- () From solder side of the board, insert the M3 x 8mm machine screw through the mounting hole at U10. On the component side of the board, Place the TO-220 heatsink's mounting hole over the protruding M3 machine screw. Make sure to align the heatsink so that it fits best on the large foil area for U10.

() Install the 7805 at U10 so that the three pre-formed leads pass through the correct holes and the mounting hole on the metal heatsink tab passes through the protruding M3 machine screw. Do not solder.

() Secure the heatsink and 7805 regulator to the board using the M3 machine screw with the M3 hex nut. Torque the nut on to the screw just enough to secure the parts. Do not over tighten.

() Verify the correct placement and alignment of the 7805 assembly and, solder the leads to the foil and cut off the excess lead lengths.

NOTE: Location J1 will be using a 40-pin socket with extended lead lengths. This socket will be installed on the bottom side of the expansion board and solder on the component side. This extended lead socket creates enough gap between the CPU and expansion boards to give needed clearance for the components on the CPU board.

The best method of establishing the correct gapping between boards will require both the CPU and expansion boards:

1. First plug the 40-pin socket with extended leads into the CPU board's 40-pin header at J1.
2. The four hex standoffs that physically setup the spacing between boards stack are installed.
3. Place the expansion board carefully on top on the CPU board so that the 40 long pins on the socket pass through the correct holes at the matching location on connector J1 of the expansion board.
4. Use four screws to attach the expansion board to the four hex standoffs. Make sure the socket is fully engaged in to J1 on the CPU board and the pins extend up to the expansion board.
5. Recheck the physical placement and pin placement then carefully sold the socket's pins into place from the component side of the expansion board.

() J1: Using the above procedure, install the 40-pin socket.

NOTE: In the following steps, install ICs (integrated circuits) in the designated sockets. Be careful to match the pin 1 end of each integrated circuits to the index mark on the socket. Before you apply downward pressure to an integrated circuit, make sure each integrated circuits pin is centered in its proper socket hole. Handle integrated circuits with care, as their pins bend very easily.

CAUTION: The integrated circuits that you will install are CMOS or MOS devices that can be damaged by static electricity. Use the following sequence when you install the integrated circuits.

1. Pick up the conductive foam block with the desired integrated circuits mounted on it.
2. Hold the IC in one hand and pull the conductive foam pad from the pins.
3. Pick up the circuit board while you hold the integrated circuits.
4. Carefully insert the IC in its socket before you set the circuit board down in to your work surface.

The IC is now protected by circuit board's sockets and foil.

NOTE: DIP = Dual Inline Package.

() U1: 74HC245 - 8 channel transceiver, 20-pin DIP

() U2: 74HC174 - D-Type positive trigger, 16-pin DIP

Retro Elf Plus

- () U3: Pre-programmed ATF22V10C, labeled "Retro ELF Expansion V:C" narrow 24-pin DIP
- () U4: 74HC04 - HEX INVERTER, 14-pin DIP
- () U5: 16550 - UART with FIFO, 40-pin DIP
- () U6: Crystal Osc. 2.4576MHz, 4-pin DIP
- () U7: MAX232A - RS232 Interface, 16-pin DIP
- () U8: 16550 - UART with FIFO, 40-pin DIP
- () U9: MAX232A - RS232 Interface, 16-pin DIP
- () U11: RTC72421 - Real Time Clock Module, 18-pin DIP

This completes the assembly of the Retro Elf Expansion Board. Now is the time to look over the finished assembly for any issues like solder bridging, unsoldered connections, cold solder joints and parts in wrong locations.

3 – Installing the Expansion Board

If you are adding the Expansion Board to an existing Retro Elf with only a CPU and Front Panel you will need to first unplug the 40-pin cable from J1 on the CPU Board and move it out of the way.

The Expansion board is designed to stack on top of the Retro Elf CPU board using four M3 x 20mm aluminum standoffs. If these four standoffs are not installed, please install them now. Just snug them a little and do not over tighten them.

The 40-pin header connector at J1, located on the back (solder) side of the Expansion Board, needs to be plugged in to the 40-pin socket J1 on the Retro Elf's CPU Board. Care needs to be taken to align the header to match the correct socket pins. Once both header and socket are fully engaged, the four mounting holes on the Expansion Board should now match up with the M3 x 20mm standoffs. Use four M3 screws to secure the Expansion Board in place to finish off the system board stack.

Next plug the 40-pin cable routing from the Retro Elf's Front Panel in to the header at J2 on the Expansion Board.

The four jumpers at JP1, JP2, JP3 and JP4 are provided to select how the Retro Elf system will be powered. In most cases the basic system of CPU, front panel, slow clock and expansion board can be powered by only the CPU's on board regulator. Installing all four jumpers will interconnect all boards and systems in to one power bus. If this option is selected, you may disregard the insulation of D4, C18, C19 and U10 on the expansion board.

In some cases you may need to power the CPU slow clock board and front panel from only the CPU's regulator. The Expansion Board with installed accessories like an external drive connected to J3 and receiving power from J8 will use the Expansion Board's regulator. If this is the case, install only JP3, JP4 and supply power between 8 and 12 volts DC to the connection at J7 on the Expansion Board.

The final installation step is to install the 3V BR1225 3 volt lithium coin cell battery that is used to power the Real Time Clock. Carefully remove the battery from any protective packaging. Note the positive and

Retro Elf Plus

negative sides of the coin cell. Insert the coin cell in to B1 so that the positive (+) side of the coin cell is on top of the battery housing under the retention spring clip.

4 – Theory of operation

Details on the revision C Retro Elf Expansion Board; such as schematics, parts list and part locations can be found in the three appendixes at the end of this document.

The 40-pin socket J1 is used as the interconnection of the expansion board to the Retro Elf's CPU board. Four 22mm M3 hex standoffs are used to space and support the expansion board in the Retro Elf system. The resulting board stack places the expansion board on top of the CPU board.

The 40-pin header J2 is used to pass through all the signaling from socket J1. There is no active electronics or isolation between J1 and J2. Since the CPU's J2 connector is used to interface the expansion board, J2 on the expansion board is now used to connect the Retro Elf's front panel.

Five volt power regulation is provided by a simple analog voltage regulator circuit made up of D4, C18, C19 and U10. Power is presented via connector J7. The positive side is passed through a 1N4001 diode labeled D4. The 1N4001 helps prevent accidental reversals on the power supply input voltage. In normal operation the 1N4001 is forward biased allowing current to flow through. If the voltage becomes reversed, the diode will be reverse biased blocking current flowing in to the regulator circuit. The 220uF electrolytic capacitor in location C18 provides some DC input voltage ripple stabilization. The 7805 regulator at U10 is used to regulate any input voltage between 8 and 16 volts DC down to a regulated 5 volts DC at up to one half amp. The 7805 should be mounted to an appropriate heat sink when input voltage are greater than 12 volts DC. The 1.2uF capacitor at C19 is used to stabilize the final regulated output voltage of the 7805.

Eleven 0.1uF capacitors (C1, C2, C3, C4, C5, C6, C7, C12, C13, C20 and C21) are used to help decouple integrated circuit generated power line noise on the 5 volt supply.

The four jumpers at JP1, JP2, JP3 and JP4 are provided to configure how the Retro Elf Plus system will be powered. Normally the complete system (CPU, front panel, slow clock and expansion boards) can be powered by the CPU board's regulator. Installing all four jumpers will interconnect all boards and systems in to one power bus. If this option is selected, you may disregard the insulation of D4, C18, C19 and U10 on the expansion board. In some cases you may need to power the CPU slow clock board and front panel separately from the expansion board. If this is the case, you only need to install JP3 and JP4.

Interfacing between the CPU and expansion boards is handled by U1, U2 and U3. U1 is an eight bit bus transceiver (74HC245) used to interface the 1802's data bus to the expansion board data bus. U2 is a hex, D-type flip-flop (74HC174) used to construct a six bit output port on input/output port 2 in the 1802 system. Port 2 is used to create more input/output control lines beyond the very limited seven supported by the native 1802 system. These new control lines will be used by all the supported devices on the expansion board. The table on the next page details each of the newly created control signals setup on port 2:

Retro Elf Plus

1802 Data Bus	Description	Name
Bit 0	Register select 0	R0
Bit 1	Register select 1	R1
Bit 2	Register select 2	R2
Bit 3	Device select 2	DS2
Bit 4	Device select 1	DS1
Bit 5	Not used	
Bit 6	Not used	
Bit 7	Device select 0	DS0

The ATF22V10C GAL located at U3, is programmed to generate the chip selects and set up control logic for each of the supported devices on the expansion board. U3 takes input signals for N0, N1, N2, -MRD TPA and TPB from the 1802 along with DS0, DS1 and DS2 from port 2 on U2. U3 then decodes these inputs to generate chip select signaling for -COM1, -COM2, PORT2, -CS1FX (ATA-3 bus), -CS3FX (ATA-3 bus). Two input/output control signals, -IORD and -IOWR, are also generated.

U5 and U8 make up two high-speed, hardware COM ports using the 16550 UART integrated circuit. A 2.4576MHz oscillator at U6 is used as a clocking source to support the internal baud rates generators on both of the 16550s. Both COM ports support hardware handshaking to support the fastest possible transfer of serial data. Four jumpers are used to select if DTR/DSR or RTS/CTS pairs will be used to support handshaking. JP9 is used to select DTR or RTS on COM 1 while JP11 is used for COM2. Likewise JP10 is used to select DSR or CTS on COM 1 while JP12 is used for COM2. One inverter on the 74HC04 (U4) along with a 1N4148 switching diode at D1 and the jumper at JP5 are used to enable 1802 interrupt support for COM1. Likewise a second inverter on the 74HC04 (U4) along with another 1N4148 switching diode at D2 and jumper JP6 support interrupt enabling for COM2. Each COM port has four diagnostics LED monitors made up of a red LED and a 1K current limiting resistor. The LEDs/resistors at locations D6/R3, D7/R4, D8/R5 and D9/R6 monitor the status of RX, TX, handshake-out and handshake-in on COM port 1. Likewise LEDs D10, D11, D12 and D13 monitor the status of RX, TX, handshake-out and handshake-in on COM port 2. Voltage level conversion for both COM channels are supplied by two MAX232A (U7 and U9) and eight 0.1uF capacitors (C8, C9, C10, C11, C14, C15, C16 and C17). Each COM channel uses four of the 0.1uF capacitors to allow each MAX232A to create a voltage pump and a voltage inverter needed to create the standard RS232 signal levels on the serial lines present at J4 (COM 1) and J5 (COM 2). This allows for easy connection to most terminals or computer serial ports supporting RS232 signaling.

The 40-pin header at J3 conforms to most of the standard ATA-3 specifications and supports many ATA devices that conform to:

1. Supporting an 8-bit transfer mode.
2. Supporting logical block addressing (LBA) mode.

This connector can be used to attach an external device like IDE disk drives or many versions of Compact Flash cards. Note: J3 is NOT buffered separately from the other electronics on the expansion board. It is

Retro Elf Plus

indeed connect to the same on-board data bus as the other chips. Care is need to limit the length of any interconnecting cables used between J3 and any externally connected devices.

Red LED D14, 470 ohm current limiting resistor R2, 2N3906 PNP transistor Q1 and 1K resistor make up a simple drive enable monitor LED of pin 39 of J3 (-DASP). The LED D14 will light whenever pin 39 is low.

Pin 31 (-INTRQ) on J3 is connected to a 1N4148 switching diode and enabling jumper JP7. When JP7 is inserted and simple diode OR gate is created out of the 1N4148 diodes. The 1802 can then receive a service interrupt from the connected device on J3.

Real-Time-Clock or RTC support is created using a Epson RTC72421 module at U11. This RTC module provides highly accurate time-keeping supporting time and date for hours, minutes, seconds, month, day, year and day-of-week. A coin cell battery socket at B1 is provided to support the use of a 3-volt battery backup for the RTC. Two low drop BAT46 Schottky diodes at D15 and D16 provide continuous operational power to the RTC even when no power is being supplied to the Retro Elf Plus.

The RTC's STD.P pin is connected to a 1N4148 switching diode and enabling jumper JP13. When JP13 is inserted a simple diode OR gate is created. The 1802 can then receive fixed-period interrupts from the RTC module.

The four pin header at J6 is supports the addition on external streaming interfaces. These interfaces can support the use of devices like audio tape recorders and streaming floppies to save programs. Pin 2 on J6 is used for input and uses JP8 is to select between -EF1 or -EF2 on the 1802. Pin 3 on J6 is an output from one inverters on the 74HC04 (U4). This inverter is used drive and invert the 1802's Q output. Pin 1 on J6 is used for +5 volts DC and pin 4 is connected to ground.

The second four pin header at J8 is used to power external devices like Flash Card interface board or IDE drives. Pin 1 is connected to the expansion boards plus 5 volt DC regulator, pin 2 and 3 are grounds while pin 4 is connected to the main voltage supplying power to the expansion board AFTER the 1N4001 protection diode D4.

5 – Technical details

J1, J2 – Retro Elf Bus

Pin	Type	Label	Description
1	Power	+5VDC	Regulated positive five volt power supply.
2	Power	+5VDC	Regulated positive five volt power supply.
3	BiDir	D0	Main system data bus bit 0.
4	BiDir	D1	Main system data bus bit 1.
5	BiDir	D2	Main system data bus bit 2.
6	BiDir	D3	Main system data bus bit 3.
7	BiDir	D4	Main system data bus bit 4.
8	BiDir	D5	Main system data bus bit 5.
9	BiDir	D6	Main system data bus bit 6.
10	BiDir	D7	Main system data bus bit 7.
11	Input	MA0	Memory Address line 0 for bits 0 or 8.
12	Input	MA1	Memory Address line 1 for bits 0 or 9.
13	Input	MA2	Memory Address line 2 for bits 0 or 10.
14	Input	MA3	Memory Address line 3 for bits 0 or 11.
15	Input	MA4	Memory Address line 4 for bits 0 or 12.
16	Input	MA5	Memory Address line 5 for bits 0 or 13.
17	Input	MA6	Memory Address line 6 for bits 0 or 14.
18	Input	MA7	Memory Address line 7 for bits 0 or 15.
19	Input	CLEAR	Main system CLEAR (aka RESET) signal.
20	Input	WAIT	Main system processor WAIT (HALT) signal.
21		DMA IN	Direct Memory Access Input.
22		DMA OUT	Direct Memory Access Output.
23	Input	N0	Input / output select line 0.
24	Input	N1	Input / output select line 1.
25	Input	N2	Input / output select line 2.
26	Input	TPA	Timing Pulse A.
27	Input	TPB	Timing Pulse B.
28	Input	CLOCK	Main system Clock.
29	Input	-MRD	Memory Read signal.
30		-WE	Memory Write Enable.
31	Input	-MWR	Memory Write signal.
32	Input	SC0	
33	Input	SC1	
34	Output	INT	Main system Interrupt.
35	Input	Q	Processor Q line output.
36	Output	EF1	Processor External Flag One input.
37	Output	EF2	Processor External Flag Two input.
38	Output	EF3	Processor External Flag Three input.
39	Ground	GND	System Ground.
40	Ground	GND	System Ground.

J3 – Simple 8-bit IDE interface bus

Pin	Type	Label	Description
1	Output	Reset	
2	Ground	GROUND	Ground.
3	BiDir	DD7	D7
4	Not Used	DD8	
5	BiDir	DD6	D6
6	Not Used	DD9	
7	BiDir	DD5	D5
8	Not Used	DD10	
9	BiDir	DD4	D4
10	Not Used	DD11	
11	BiDir	DD3	D3
12	Not Used	DD12	
13	BiDir	DD2	D2
14	Not Used	DD13	
15	BiDir	DD1	D1
16	Not Used	DD14	
17	BiDir	DD0	D0
18	Not Used	DD15	
19	Ground	GROUND	Ground.
20	Void	Key	No pin.
21	Not Used	DMARQ	
22	Ground	GROUND	Ground.
23	Output	DLOW	IOWR
24	Ground	GROUND	Ground.
25	Output	DIOR	IORD
26	Ground	GROUND	Ground.
27	Not Used	IORDY	
28	Not Used	CSEL	
29	Not Used	DMACK	
30	Ground	GROUND	
31	Input	INTRQ	INT
32	Not Used	IOCS16	
33	Output	DA1	R1
34	Not Used	PDIAG	
35	Output	DA0	R0
36	Output	DA2	R2
37	Output	CS1FX	CS1FX
38	Output	CS3FX	CS3FX
39	Not Used	DASP	
40	Ground	GROUND	Ground.

J4, J5 - RS232 Serial ports pinout

There are two RS-232-C serial connectors labeled J4 and J5. Both connectors conform to the EIA (Electronic Industries Association) RS-232-C (August 1969) standards and should work with any terminal or computer serial interface support this standard.

The RS-232-C standard defines the voltage levels that correspond to logical one and logical zero levels for the data transmission and the control signal lines. Valid signals are either in the range of +3 to +15 volts or the range -3 to -15 volts with respect to the Common Ground (GND) pin. The range between -3 to +3 volts is not a valid RS-232-C level.

The MAX232A serial interface integrated circuits used within the interface, fully supports RS-232-C serial input signals covering the complete range defined in the standard. The MAX232A drives the serial outputs levels of about +9 for a space (0) and -9 for a mark (1). These output signal levels again fall nicely within the RS-232-C standard.

Pin	Type	Label	Description
1	Input	RCV	RS232 serial data receive.
2	Input	DSR/CTS	RS232 serial DSR or CTS handshake signal.
3	Output	XMT	RS232 serial data transmit.
4	Output	DTR/RTS	RS232 serial DTR or RTS handshake signal.
5	Ground	Ground	Common ground.

J6 – Accessory device interface

J6 is used to support the addition on external streaming interfaces. These interfaces include devices to save programs or data and include audio tape interfaces and streaming floppies. Pin 2 is used for input and can be configured by JP8 is to select between the CDP1802's EF1 or EF2 signal lines. Pin 3 is an output from one inverters on the 74HC04 (U4). This inverter is used drive and invert the CDP1802's Q output signal line. Pin 1 (+5VDC) and 4 (ground) are used to provide the power requirements on any external interface electronics.

Pin	Type	Label	Description
1	Power	+5VDC	+5 volts DC power source.
2	Input	EF	CDP1802 EF signal input.
3	Output	Q	CDP1802 Q signal output.
4	Output	Ground	Common ground.

J7 – Expansion board power

Pin	Type	Label	Description
1	Power	+V	Main expansion board power supply +8 to 16VDC at 1A maxum.
2	Ground	Ground	Power ground.

J8 – Accessory device power feed

J8 is used to power external devices like Flash Card interface board or IDE drives. Pin 1 is connected to the expansion boards plus 5 volt DC regulator, pin 2 and 3 are grounds while pin 4 is connected to the main voltage supplying power to the expansion board AFTER the 1N4001 protection diode D4.

Retro Elf Plus

Pin	Type	Label	Description
1	Power	+5VDC	+5 volts DC power source.
2	Ground	Ground	Power ground.
3	Ground	Ground	Power ground.
4	Power	+V	This line is connected to the expansion board power after the D4 diode.

Appendix A - Schematics

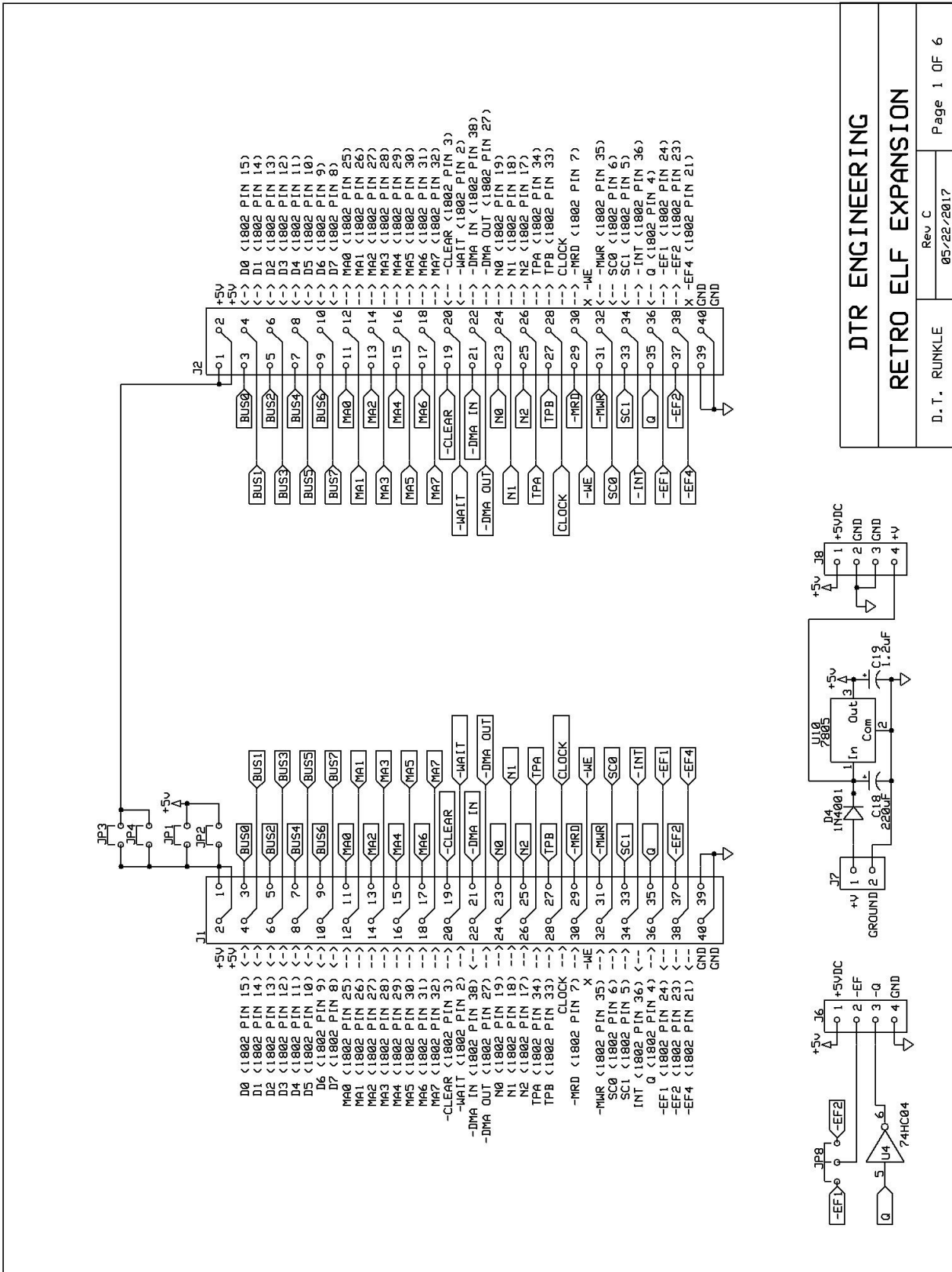

DTR ENGINEERING

RETRO ELF EXPANSION

Rev C
05/22/2017

D. T. RUNKLE

Page 1 OF 6

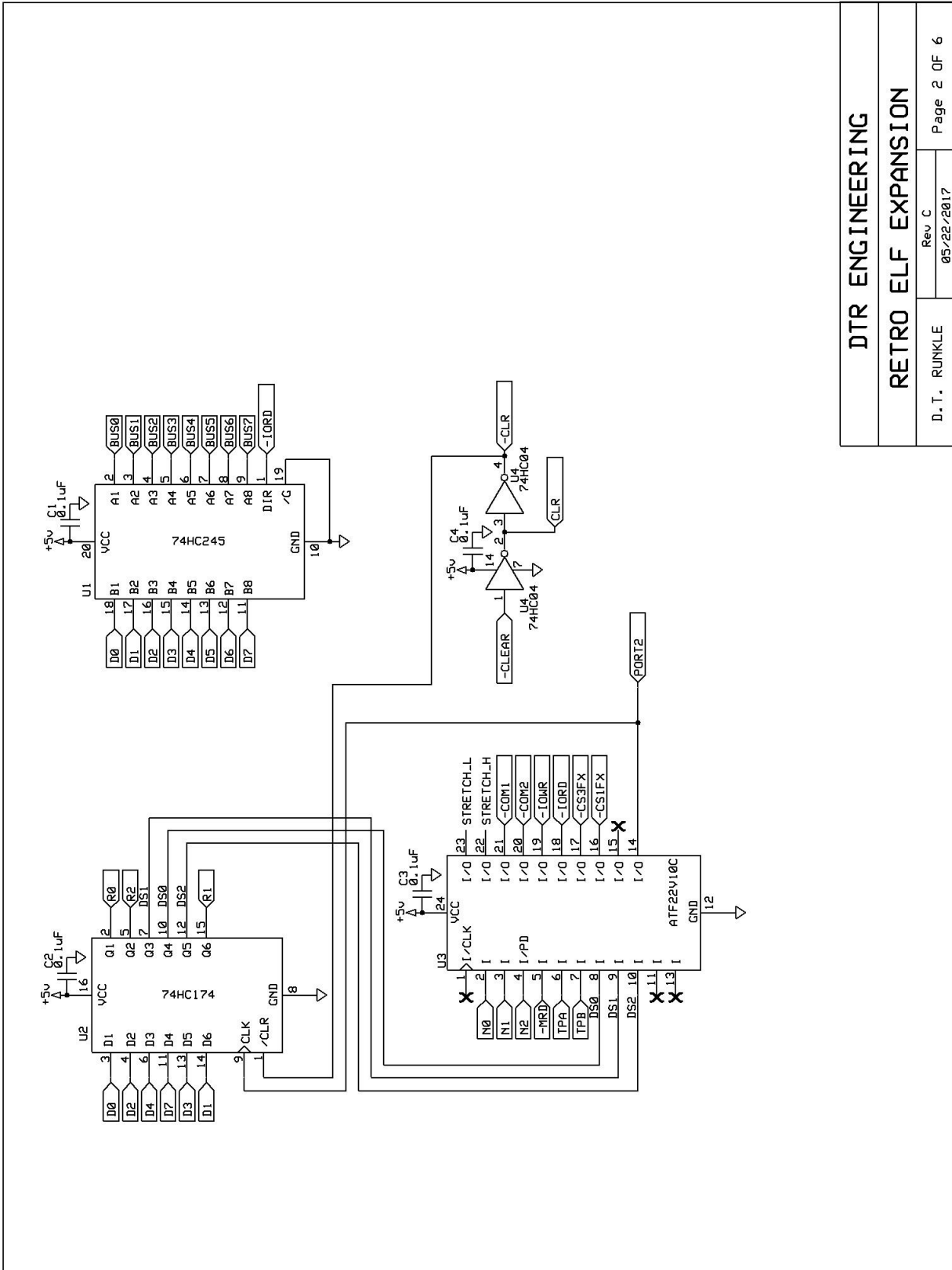

DTR ENGINEERING	
RETRO ELF EXPANSION	
D. T. RUNKLE	Rev C 05/22/2017
Page 2 OF 6	

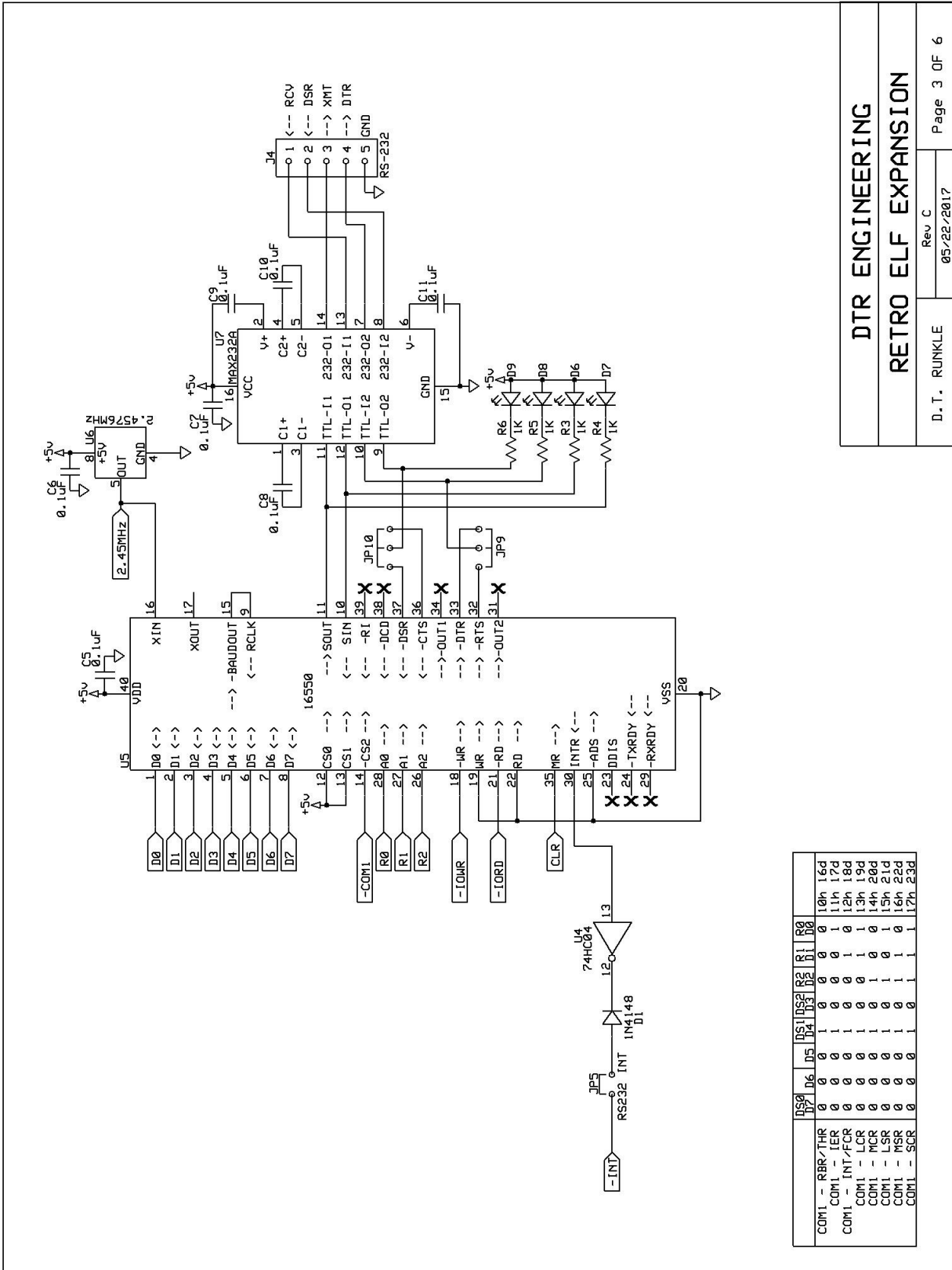

D.T. RUNKLE
Rev C
05/22/2017
Page 3 OF 6

DTR ENGINEERING
RETRO ELF EXPANSION

COM1 - RBR/THR	D7	D6	D5	D4	D3	D2	D1	R0
COM1 - IER	0	0	0	0	0	0	0	10h 16d
COM1 - INT/FCR	0	0	0	0	0	0	0	11h 17d
COM1 - LCR	0	0	0	0	0	0	0	12h 18d
COM1 - MCR	0	0	0	0	0	0	0	13h 19d
COM1 - LSR	0	0	0	0	0	0	0	14h 20d
COM1 - MSR	0	0	0	0	0	0	0	15h 21d
COM1 - SCR	0	0	0	0	0	0	0	16h 22d
								17h 23d

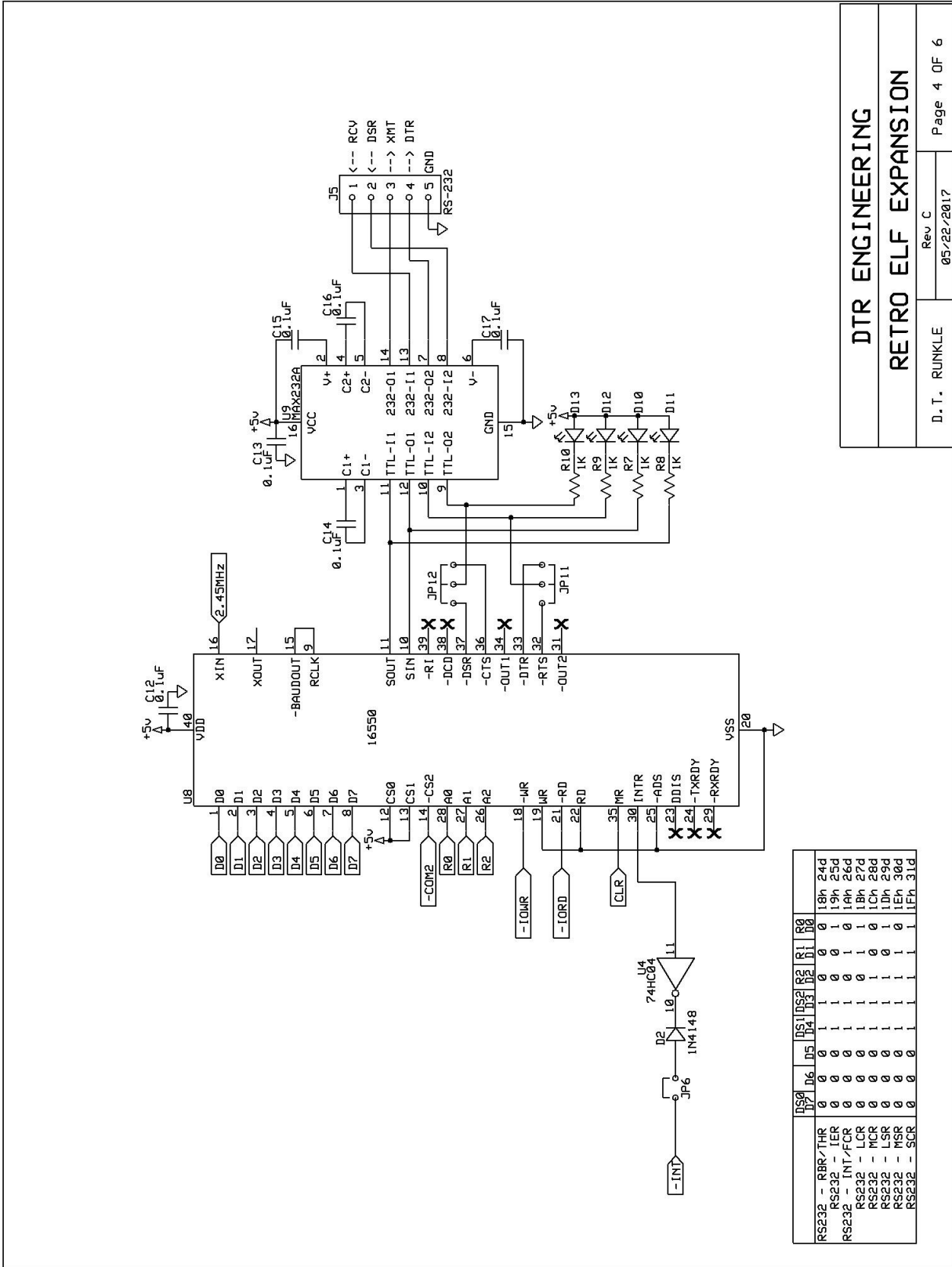

DTR ENGINEERING

RETRO ELF EXPANSION

D. T. RUNKLE Rev C 05/22/2017 Page 4 OF 6

	(CS1)	(A3)	(A2)	(A1)	(A0)	PORT 2 ADDRESS
	D7	D3	D2	D1	D0	
S1	1	0	0	0	0	80h (128d)
S10	1	0	0	0	1	81h (129d)
M1	1	0	0	1	0	82h (130d)
M10	1	0	0	1	1	83h (131d)
H1	1	0	1	0	0	84h (132d)
H10	1	0	1	0	1	85h (133d)
D1	1	0	1	1	0	86h (134d)
D10	1	0	1	1	1	87h (135d)
M11	1	1	0	0	0	88h (136d)
M101	1	1	0	0	1	89h (137d)
Y1	1	1	1	0	0	8Ah (138d)
Y10	1	1	1	0	1	8Bh (139d)
M	1	1	1	1	0	8Ch (140d)
CD	1	1	1	1	1	8Dh (141d)
CE	1	1	1	1	0	8Eh (142d)
CF	1	1	1	1	1	8Fh (143d)

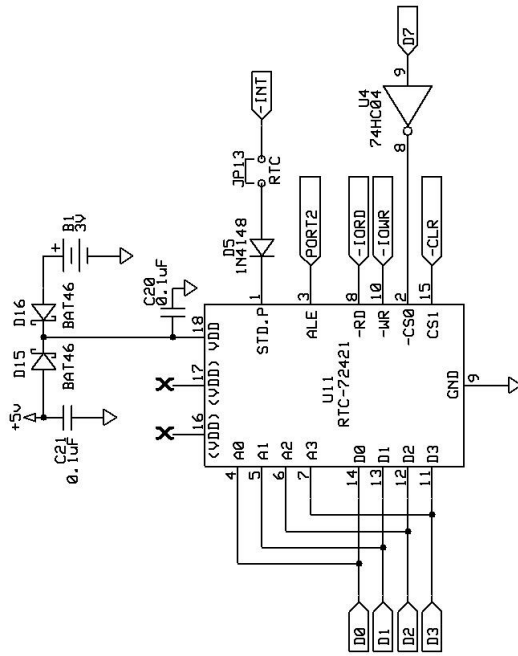

Retro Elf Plus

Appendix B – Parts list

Location	Qty	Description	Vendor	Vendor PN	MFG	MFG PN
B1	1	Holder battery PC Coin Cell 12mm	Digi-Key	36-500-ND	Keystone	500
B1	1	Lithium battery 3V Coin 12.5mm	Digi-Key	P183-ND		BR-1225
C1, C2, C3, C4, C5, C6, C7, C8, C9, C10, C11, C12, C13, C14, C15, C16, C17, C20, C21	19	Capacitor CER 0.1uF 50V 20% Radial	Digi-Key	399-4151-ND	Kemet	C315C104M5U5TA
C18	1	Capacitor alum 220uF 20% 16V axia	Digi-Key	TVX1C221MAD-ND	Nichicon	TVX1C221MAD
C19	1	Capacitor 1.2uF Tantalum	Digi-Key	399-3533-ND	Kemet	T350A155K025AT
D1	1	Diode 1N4001 General Purp 50V 1A DO41	Digi-Key	1N4001GOS-ND	ON Semiconductor	1N4001G
D6, D7, D8, D9, D10, D11, D12, D13, D14	9	1 3/4 RED LED	Digi-Key	754-1266-ND	Kingbright	WP7113LUD
D1, D2, D3, D5	4	Diode 1N4148	Digi-Key	1N4148TACT-ND	Fairchild	1N4148TA
D15, D16	2	Diode Schottky BAT46	Digi-Key	497-3768-1-ND	STMicoelectronics	BAT46
J1	1	Socket 2x20, 2.54mm pitch, 10.5mm pins	Digi-Key	1528-1385-ND	Adafrint Industries	2223
J2, J3	2	Header 40 pin 2 x 20, 0.1 pitch	Digi-Key	WM8134-ND	Molex Inc	901310140
J4, J5	2	Connector header 5 position 0.1 pitch vertical tin	Digi-Key	WM4203-ND	Molex Inc	22232051
J6, J8	2	Connector header 4 position 0.1 pitch vertical tin	Digi-Key	WM4202-ND	Molex Inc	22232041
J7	1	Connector header 2 position 0.1 pitch vertical tin	Digi-Key	WM4200-ND	Molex Inc	22232021
JP1, JP2, JP3, JP4, JP5, JP6, JP7, JP8, JP9, JP10, JP11, JP2, JP13	13	Jumper SKT Black	Digi-Key	952-2165-ND	Harwin Inc	M7567-46
JP1, JP2, JP3, JP4, JP5, JP6, JP7, JP8, JP9, JP10, JP11, JP2, JP13	8	Connector header vertical 2-position 0.1 gold	Digi-Key	3M9457-02-ND	3M	961102-6404-AR
JP8, JP9, JP10, JP11, JP12	5	Connector header vertical 2-position 0.1 gold	Digi-Key	3M9457-03-ND	3M	961103-6404-AR
PWB	1	PC Board, Retro ELF Plus - Expansion Board	DTR Eng	NA	NA	NA
Q1	1	2N3906		2N3906FS-ND	Fairchild	2N3906BU
R1, R3, R4, R5, R6, R7, R8, R9, R10	9	Resistor 1Kohm, 5%, 1/8 Watt	Digi-Key	CF18JT1K00CT-ND	Stackpole	CF18JT1K00
R11, R12	2	Resistor 4.7Kohm, 5%, 1/8 Watt	Digi-Key	CF18JT4K70CT-ND	Stackpole	CF18JT4K70
R2	1	Resistor 470ohm, 5%, 1/8 Watt	Digi-Key	CF18JT470RCT-ND	Stackpole	CF18JT470R
U1	1	74HC245 - IC 8 channel transceiver, 20- DIP	Digi-Key	296-1584-5-ND	Texas Instruments	SN74HC245N
U2	1	74HC174 - IC D-Type positive trigger, 16- DIP	Digi-Key	296-1579-5-ND	Texas Instruments	SN74HC174N
U3	1	ATF22V10C "Retro ELF Expansion V:C"	Digi-Key	ATF22V10C-15PU-ND	Atmel	ATF22V10C-15PU
U4	1	74HC04 - IC HEX INVERTER 14-DIP	Digi-Key	296-1566-5-ND	Texas Instruments	SN74HC04N
U5, U8	2	16550 - IC UART with FIFO, 40-DIP	Digi-Key	PC16550DN/NOPB-ND	Texas Instruments	PC16550DN/NOPB
U6	1	Crystal Osc. 2.4576MHz	Digi-Key	XC233-ND	ECS Inc	ECS-2100A-024
U7, U9	2	MAX232A - IC RS232 Interface, 16-DIP	Digi-Key	MAX232ACPE+-ND	Maxim Integrated	MAX232ACPE+

Retro Elf Plus

U10	1	LM7805 - +5 Volt Regulator	Digi-Key	MC7805CT-BPMS-ND	Micro Commercial	MC7805CT-BP
U11	1	RTC72421 - IC Real Time Clock Module	Digi-Key	SER3231-ND	Epson	RTC-72421A:ROHS
U6	1	Socket IC 8-Pin	Digi-Key	AE10011-ND	Assmann WSW	AR-08-HZL-TT
U4	1	Socket IC 14 Pin	Digi-Key	AE10012-ND	Assmann WSW	AR-14-HZL-TT
U2, U7, U9	3	Socket IC 16 Pin	Digi-Key	AE10013-ND	Assmann WSW	AR-16-HZL-TT
U11	1	Socket IC 18 Pin	Digi-Key	AE10014-ND	Assmann WSW	AR-18-HZL-TT
U1	1	Socket IC 20 Pin	Digi-Key	AE10015-ND	Assmann WSW	AR-20-HZL-TT
U3	1	Socket IC 24 Pin 0.3 inch width	Digi-Key	AE10027-ND	Assmann WSW	AR-24-HZL-TT
U5, U8	2	Socket IC 40 Pin	Digi-Key	AE10018-ND	Assmann WSW	AR-40-HZL-TT
U10	1	Heatsink TO-220	Digi-Key	HS107-ND	Aavid Thermolloy	577202B00000G
U10	1	Machine screw PAN Phillips M3x8mm	Digi-Key	335-1149-ND	APM Hexseal	RM3X8MM 2701
U10	1	Hex nut M3	Digi-Key	H762-ND	B&F Fastener	MHNZ 003

Appendix C – Printed Circuit Board parts locations

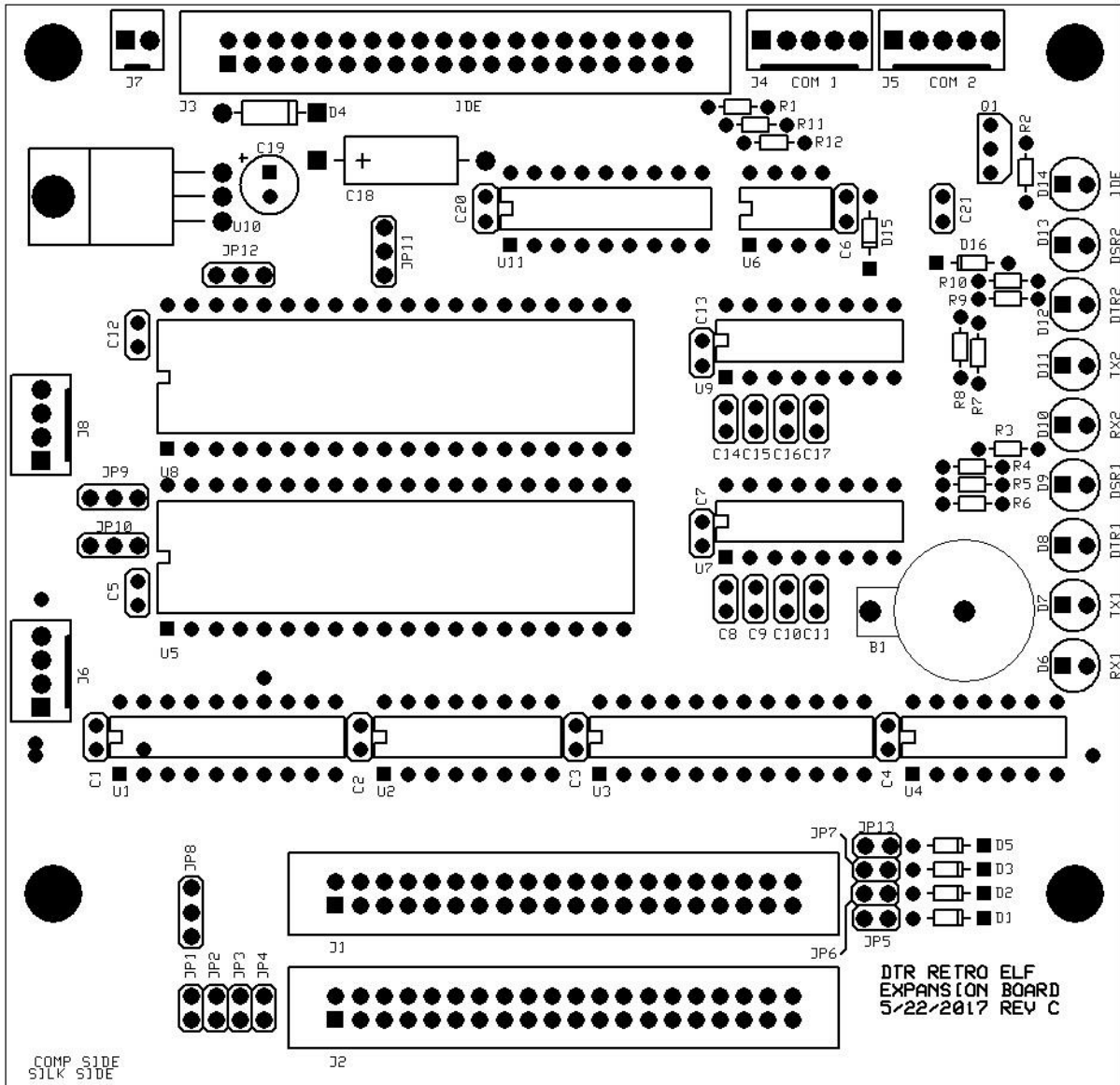

Appendix D – Connectors and Jumpers

