

## Retro Elf Plus



Retro Elf Plus - CPU Board - Revision C

Copyright © 2016 through 2018 by D.T.Runkle  
Website at [www.astrorat.com](http://www.astrorat.com)

Permission is granted to copy, distribute and/or modify this document under the terms of the GNU Free Documentation License, Version 1.1 published by the Free Software Foundation. A copy of this license may be obtained from <http://www.gnu.org/licenses/fdl.txt>.

## 1 – About the CPU board

The CPU board is not depended on the front panel allowing use in standalone applications. Here is located the heart of Retro Elf, the 1802 microprocessor and its supporting electronics.

The use of low power CMOS components helps keep the board's power needs to a minimum. The CPU board only uses 95mA of current with a 12-volt DC power supply. A simple on board 5-volt DC voltage regulator is implemented to power the complete system (CPU, slow clock board, front panel and expansion board). This regulator can supply 5 volts at up to half an amp when an 8-12 volts DC input is supplied to the board. A protection diode is used to help protect against accidental reversal of input power.

The system clock is provided by an on-board oscillator module. The labeled oscillator module frequency is divided by two before entering the 1802. So, if the oscillator is rated 6MHz the 1802 would see 3MHz. One interesting feature of the 1802's CMOS architecture is the capability to operation at any frequency from DC up to the processor's rated frequency. You can even vary the frequency at any time. The optional Slow Clock board takes advantage of this and can adjust the processor frequency during operation allowing you to see each fetch and execute cycle operation of running code via the front panel.

All 64K bytes of supported memory has been split in to two 32K chunks and have been addressed in to two chip sockets. On-board jumpers provided configurability for each of the two sockets as needed. The most common default setup has a static RAM in the first socket addressed from 0000H to 7FFFH and EEPROM/EEPROM used the second socket addressed from 8000H to FFFFH.

An on board "boot-strap" circuit is provided. When enabled, the 1802 is tricked in to start running code from 8000H after a clear (reset). A jumper selectable boot-strap clear signal can come from either a high on the 1802's Q line or any I/O operation.

An on-board battery backup circuit is also implemented to provide 3V DC to SRAM when normal power is lost. The use of a low power CMOS SRAM should be used to allow for a normal standby battery life.

Simple software (bit-banging) serial can be provided using the 1802's Q output line and one of the four jumper selectable EF input lines. Both the serial input and output can be setup as normal or inverted again via on board jumpers. A MAX232A integrated circuit is use to create standard RS232 signal level on the serial lines. This allows for easy connection to most terminals or computer serial ports supporting RS232 signaling.

The 40-pin expansion header brings out most of the 1802's signal lines as well as a 5-volt DC power source. It is via this header that the front panel will be connected in addition to any other future expansion boards that may come. Two groups of status LEDs have been provided to indicate operational status of the CPU board. The group of four LEDs provide status on the boot-strap circuit, the +5VDC power, serial RXD and serial TXD (aka 1802's Q LED). The group of three LEDs provide processor status; RUN, WAIT and RESET. If all three LEDs are off the microprocessor is in a LOAD mode not normally seen while in standalone operation.

## 2- Assembly

### Before you begin, some helpful hints

Follow the instructions carefully and read the entire step before you perform the operation. Solder a part or group of parts only when you are instructed to do so.

Each circuit part in an electronic kit has its own component number (R2, C4, etc.). Use these numbers when you want to identify that same part in the various sections of the Manual. These numbers, which are especially useful if a part has to be replaced, appear:

- In the Parts List
- At the beginning of each step where a component is installed
- In the schematic

**SAFETY WARNING:** *Safety glasses are recommended. Avoid eye injury when you cut off excess lead lengths. Hold the leads so they cannot fly toward your eyes.*

### Soldering

Soldering is one of the most important operations you will perform while assembling your kit. A good solder connection will form an electrical connection between two parts, such as a component lead and a circuit board foil. A bad solder connection could prevent an otherwise well-assembled kit from operating properly.

It is easy to make a good solder connection if you follow a few simple rules:

- Use the right type of soldering iron. If available, a temperature controlled soldering iron is recommended. Otherwise use a 25 to 40-watt pencil soldering iron. In either case use a 1/8" or 3/16" chisel or pyramid tip for best results.
- Keep the soldering iron tip clean. Wipe it often on a wet sponge or cloth; then apply solder to the tip to give the entire tip a wet look. This process is called tinning, and it will protect the tip and enable you to make good connections. When solder tends to "ball" or does not stick to the tip, the tip needs to be cleaned and retinned.
- Use only a high quality rosin-core, 62/36/2 silver-bearing solder with a 0.020 or 0.015 inch diameter.
- A good solder connection is made when you heat the component lead and the foil on the circuit board at the same time. This will allow the solder to flow evenly onto the lead and foil. The solder will then make a good electrical connection between the lead and the foil.

### Board Assembly

Refer to the silk screen on the printed circuit board or the Board Layout in Appendix C for parts locations on the board.

Install the ten 1/8 watt resistors at the following locations.

( ) R1: 1K ohm, 1/8-watt, 5% (brown-black-red)

( ) R2: 1K ohm, 1/8-watt, 5% (brown-black-red)

( ) R3: 1K ohm, 1/8-watt, 5% (brown-black-red)

## Retro Elf Plus

- ( ) R4: 1K ohm, 1/8-watt, 5% (brown-black-red)
- ( ) R5: 1K ohm, 1/8-watt, 5% (brown-black-red)
- ( ) R6: 1K ohm, 1/8-watt, 5% (brown-black-red)
- ( ) R7: 1K ohm, 1/8-watt, 5% (brown-black-red)
- ( ) Solder the leads to the foil and cut off the excess lead lengths

**NOTE:** *The next two diodes are polarized and need to be installed with the banded end matching the outline on the PC board or the board layout. The lead on the banded in should be inserted into the square hole on the PC board.*

- ( ) D1: Black diode labeled 1N4001
- ( ) D5: Orange colored glass diode labeled 1N4148
- ( ) Solder the leads to the foil and cut off the excess lead lengths.

Install the fourteen capacitors at the following locations.

- ( ) C1: 0.1uF ceramic (sometimes labeled 104)
- ( ) C2: 0.1uF ceramic (sometimes labeled 104)
- ( ) C3: 0.1uF ceramic (sometimes labeled 104)
- ( ) C4: 0.1uF ceramic (sometimes labeled 104)

**Note:** *Capacitors C5 and C6 will be installed in a later step.*

- ( ) C7: 0.1uF ceramic (sometimes labeled 104)
- ( ) Solder the leads to the foil and cut off the excess lead lengths.
- ( ) C8: 0.1uF ceramic (sometimes labeled 104)
- ( ) C9: 0.1uF ceramic (sometimes labeled 104)
- ( ) C10: 0.1uF ceramic (sometimes labeled 104)
- ( ) C11: 0.1uF ceramic (sometimes labeled 104)
- ( ) C12: 0.1uF ceramic (sometimes labeled 104)
- ( ) Solder the leads to the foil and cut off the excess lead lengths.
- ( ) C13: 0.1uF ceramic (sometimes labeled 104)
- ( ) C14: 0.1uF ceramic (sometimes labeled 104)
- ( ) C15: 0.1uF ceramic (sometimes labeled 104)
- ( ) C16: 0.1uF ceramic (sometimes labeled 104)

## Retro Elf Plus

- ( ) C17: 0.001uF ceramic (sometimes labeled 102)
- ( ) Solder the leads to the foil and cut off the excess lead lengths.

**NOTE:** 8-pin, 14-pin, 16-pin, 20-pin, 28-pin and 40-pin IC (integrated circuit) sockets are used in this kit. Make sure all pins are straight. Carefully insert the socket pins in to the circuit board holes. Make sure that the index notch on the IC socket is on the same end as pin one (a square pad indicates pin 1) of that IC's location. All sockets are placed on the component side and soldered on the solder side of the board. Start by soldering only a single pin to the board. Verify that the socket is aligned and tight against the component side of the board. If not, carefully reheat the pin and reposition the IC socket as needed. Once the IC socket is correctly placed, solder the remaining pins.

- ( ) U1: Install a 40-pin IC socket.
- ( ) U2: Install a 20-pin IC socket.
- ( ) U3: Install a 28-pin IC socket.
- ( ) U4: Install a 28-pin IC socket.
- ( ) U6: Install a 14-pin IC socket.
- ( ) U7: Install a 16-pin IC socket.
- ( ) U10: Install a 14-pin IC socket.
- ( ) U11: Install a 8-pin IC socket.
- ( ) U12: Install a 20-pin IC socket.

**NOTE:** The next three parts are serial-inline-package or SIP resistors. These parts must be oriented correctly for the Retro Elf to work. On each SIP resistor there will be a small dot or line indicating pin one on the SIP. The SIP must be oriented so the indicated pin one is placed into the hole with the square pad outlined by a square box in the silkscreen around this pad. Like the sockets above, start by soldering only a single pin to the board. Verify that the SIP is aligned and tight against the component side of the board. If not, carefully reheat the pin and reposition the SIP as needed. Once the SIP is correctly placed, solder the remaining pins.

- ( ) RN1: Install a 10-Pin, 22K x 9, SIP resistor.
- ( ) RN2: Install a 6-Pin, 10K x 5, SIP resistor.
- ( ) RN3: Install a 6-Pin, 10K x 5, SIP resistor.

**CAUTION:** The 6MHz oscillator module you will be installing in the next step is a CMOS device that can be damaged by static electricity. Use the following sequence when you install this oscillator integrated circuits.

1. Pick up the conductive foam block with the oscillator mounted on it.
2. Hold the oscillator in one hand and pull the conductive foam pad from the pins and set the foam pad aside.

## Retro Elf Plus

3. Pick up the circuit board while you hold the oscillator.

4. Carefully insert the oscillator in indicated holes. Make sure to install the oscillator in the correct orientation on the board. Carefully bend the leads just enough to hold the oscillator in place before you set the circuit board down in to your work surface for soldering.

5. Verify that the oscillator is in the correct orientation and solder the four oscillator leads to the board and trim as needed.

*The oscillator is now protected by circuit board's sockets foil.*

( ) U9: Install a 6MHz crystal oscillator module.

**NOTE:** The next two capacitors are polarized and have positive and negative leads. Make sure that the positive lead is inserted into the hold marked + (the square hole) on the board.

( ) C5: 220uF polarized aluminum electrolytic capacitor.

( ) C6: 1uF polarized tantalum capacitor.

**NOTE:** Installing the LEDs, position the flat side as shown to match the outline on the board. Note that the short LED lead is in the square hole on the board. Hold the LEDs tight to the board and solder the leads to the foil and cut off the excess lead lengths.

( ) D2: Red LED at location labeled TXD.

( ) D3: Red LED at location labeled RXD.

( ) D4: Green LED at location labeled PWR.

( ) D6: Yellow LED at location labeled BOOT.

( ) D7: Red Green at location labeled RUN.

( ) D8: Red Yellow at location labeled WAIT.

( ) D9: Red LED at location labeled RESET.

**Note:** When installing the next 40-pin header, make sure to install the 40-pin header so that pin 1 is in the hole with the square pad on the board. Solder only one pin then verify that the header is align and tight to the board and pin 1 is in the correct hole. Then solder the remaining pins.

( ) J2: Install a 40-pin header

( ) J1: 5-pin header. Match the silk screen or board layout and solder.

( ) J3: 2-pin header. Match the silk screen or board layout and solder.

( ) JP1: 2-pin jumper header. Match the silk screen or board layout and solder.

( ) JP2: 2-pin jumper header. Match the silk screen or board layout and solder.

( ) JP3: 2-pin jumper header. Match the silk screen or board layout and solder.

( ) JP4: 2-pin jumper header. Match the silk screen or board layout and solder.

## Retro Elf Plus

- ( ) JP5: 2-pin jumper header. Match the silk screen or board layout and solder.
- ( ) JP6: 2-pin jumper header. Match the silk screen or board layout and solder.
- ( ) JP7: 3-pin jumper header. Match the silk screen or board layout and solder.
- ( ) JP8: 3-pin jumper header. Match the silk screen or board layout and solder.
- ( ) JP9: 2-pin jumper header. Match the silk screen or board layout and solder.
- ( ) JP10: 2-pin jumper header. Match the silk screen or board layout and solder.
- ( ) JP11: 2-pin jumper header. Match the silk screen or board layout and solder.
- ( ) JP12: 2-pin jumper header. Match the silk screen or board layout and solder.
- ( ) JP13: 2-pin jumper header. Match the silk screen or board layout and solder.
- ( ) JP14: 2-pin jumper header. Match the silk screen or board layout and solder.
- ( ) JP15: 2-pin jumper header. Match the silk screen or board layout and solder.
- ( ) JP16: 3-pin jumper header. Match the silk screen or board layout and solder.
- ( ) JP17: 3-pin jumper header. Match the silk screen or board layout and solder.
- ( ) JP18: 3-pin jumper header. Match the silk screen or board layout and solder.
- ( ) JP19: 2-pin jumper header. Match the silk screen or board layout and solder.
- ( ) JP20: 2-pin jumper header. Match the silk screen or board layout and solder.
- ( ) JP21: 2-pin jumper header. Match the silk screen or board layout and solder.

**NOTE:** *The next part installed is a DS1233. This integrated circuit is packaged in a TO-92 style case and look like a transistor.*

**CAUTION:** *If the DS1233 is installed backwards, it will be destroyed on powerup. When installing the DS1233, make sure to align the 3-pin package so the flat side of the part matches the outline on the board's silk screen or the board layout in the appendix.*

( ) U8: Align the DS1233 IC to the silk screen on the board or board layout. Insert each of the 3-pin in to their respective holes and carefully push the part to about 0.1 inches above the board. Bend the leads slightly on the back to hold the part in place.

( ) SW1: Install the CLEAR button.

( ) B1: 12mm battery holder. Match the silk screen or board layout and solder. Do not install the battery at this time.

( ) U5: Locate the following four parts used to assemble the 7805 voltage regulator to the board:

- Phillips machine screw, M3 x 8mm
- Hex Nut, M3

## Retro Elf Plus

- TO-220 heatsink
- IC, 7805 5 volt regulator in a TO-220 case

( ) The three leads on the 7805 need to be pre-bent before installation. Notice that the leads on the 7805 are wider where they exit the black body of the 7805 and then narrow down. Where the transition from wide to narrow occurs, bend the three leads down towards the metal heat sink side of the 7805 to an angle of 90 degrees. Temporarily set the 7805 aside until required.

( ) From solder side of the board, insert the M3 x 8mm machine screw through the mounting hole at U5. On the component side of the board, Place the TO-220 heatsink's mounting hole over the protruding M3 machine screw. Make sure to align the heatsink so that it fits best on the large foil area for U5.

( ) Install the 7805 at U5 so that the three pre-formed leads pass through the correct holes and the mounting hole on the metal heatsink tab passes through the protruding M3 machine screw. Do not solder.

( ) Secure the heatsink and 7805 regulator to the board using the M3 machine screw with the M3 hex nut. Torque the nut on to the screw just enough to secure the parts. Do not over tighten.

( ) Verify the correct placement and alignment of the 7805 assembly and, solder the leads to the foil and cut off the excess lead lengths.



### Testing

Before we install the ICs or battery; we will perform a few basic powerup tests.

( ) Carefully check for any solder bridges between pins and foil pads. If a solder bridge has occurred, hold the circuit board solder side down and hold the soldering iron tip between the two points that are bridged. The solder will flow down the soldering iron tip.

( ) Verify that all parts are in their correct locations.

( ) Set an ohm meter to read the lowest resistance setting and measure across the two pins on J3. If the resistance reading is close to zero then some form of electrical short exists. Carefully inspect the board assembly for solder bridges or parts installed backwards or at incorrect locations. Correct any issues found and re perform this test.

( ) Reverse the meter leads on J3 and reread the resistance. Like before, if the reading is close to zero then some form of electrical short exists. Carefully inspect the board assembly for solder bridges or parts installed backwards or at incorrect locations. Correct any issues found and re perform this test.

( ) In this step we will be using a bench or other 8 to 16-volt DC power supply able to supply ½ amp of current. Make sure the power supply is off. Connect the positive lead from the power supply to pin 1 on J3 (the pin with the square pad) and the negative lead to pin 2.

( ) Set a voltmeter to read a positive 5-volts reading on the DC range. Connect the positive lead of the voltmeter to pin 20 on U2 and the negative lead to pin 10.

( ) Turn on the power supply and note the reading on the voltmeter. You should be reading a positive DC voltage between 4.9 and 5.1 volts. The green PWR (power) LED should be on. Turn off the power supply.

( ) If you plan on using the battery backup option, install a battery at location B1 and then insert the two pin shorting jumper at JP19.

( ) Set a voltmeter to read a positive 3-volts on the DC range. Measure the voltage reading between the positive pin 2 on U11 and the negative pin 7 on U11. You should have a reading between 2 and 3.5 volts DC while the main DC power is turned off.

( ) Disable the battery power by removing the shorting jumper at JP19.

### Final assembly

**NOTE:** In the following steps, install ICs (integrated circuits) in the designated sockets. Be careful to match the pin 1 end of each integrated circuit to the index mark on the socket. Before you apply downward pressure to an integrated circuit, make sure each integrated circuit pin is centered in its proper socket hole. Handle integrated circuits with care, as their pins bend very easily.

**CAUTION:** The integrated circuits that you will install are CMOS or MOS devices that can be damaged by static electricity. Use the following sequence when you install the integrated circuits.

1. Pick up the conductive foam block with the desired integrated circuits mounted on it.
2. Hold the IC in one hand and pull the conductive foam pad from the pins.
3. Pick up the circuit board while you hold the integrated circuits.

4. *Carefully insert the IC in its socket before you set the circuit board down in to your work surface.*

The IC is now protected by circuit board's sockets and foil.

**NOTE:** *DIP = Dual Inline Package.*

( ) U1: CDP1802 - , 40-pin DIP

( ) U2: 74HC373 - , 20-pin DIP

( ) U3: AS6C62256 - , 28-pin DIP

( ) U4: AT28C256 - , 28-pin DIP

( ) U6: 74HC04 - , 14-pin DIP

( ) U7: MAX232 - , 16-pin DIP

( ) U10: 74HC74 - , 14-pin DIP

( ) U11: DS1210 - , 8-pin DIP

( ) U12: Pre-Programmed GAL 16V8 labeled "Retro ELF CPU Ver:C" - , 20-pin DIP

This completes the assembly of the Retro Elf CPU Board. Now is the time to take a last look over the finished assembly once more looking for any issues like bent pins under ICs, unsoldered connections, cold solder joints and parts in wrong locations.

### 3– Theory of operation

Details on the revision C CPU board such as part locations, parts list and schematics, are located in appendix A.

The core of the CPU board and of the Retro Elf project itself, is the CDP1802 microprocessor (U1) originally developed by RCA in 1975. All other electronics on the CPU board are designed to support the operation of U1.

Over time variants of the 1802 were created that were mostly pin compatible to the original. Jumper JP6 is provided to allow support for these other versions of the family. If a classic CDP1802 is used, JP6 must be installed.

The 1802's clock is supplied by the clock circuit made up of an oscillator module (U9) and one half of a 74HC74, D flip-flop (U10). The 74HC74 is setup to divide the original oscillator frequency by two. So, if the oscillator is 6MHz, after the 74HC74 the 1802 would receive an input clock of 3MHz.

The 1802's -CLEAR is held high using one of the 10K resistors in resistor network RN2. Resetting the 1802 is then accomplished by pulling the -CLEAR line low. Power-on-clear and on-board reset button de-bouncing is supplied by a DS1233 (U8). The DS1233 has an open collector output. It monitors the power supply voltage and will pull and hold the 1802's -CLEAR line low until a safe operational voltage is restored. The DS1233 will also act as a de-bounce circuit for reset button (SW1). The 0.001uF (C17) capacitor helps the DS1233 setup proper de-bounce timing when SW1 is pressed to clear the 1802.

The 1802's eight data bus lines are pulled high by the 22K resistor network RN1. This helps place the data bus in a known state during high impedance operations when no device is using the data bus. Likewise, 10K resistor networks RN2 and RN3 are used to pull high all four EF inputs along with the -CLEAR, -WAIT, -INTERRUPT, -DMAIN and -DMA-OUT signals.

Since the 1802 uses a multiplexed address bus, some form of high address range latch is needed to latch the high address lines A8-A15. This operation is handled by a 74HC373 (U2). The 1802 uses the TPA control line to signal latching. The falling edge of TPA latches the high eight bits of the address in to the 74HC373.

The full 64K of 1802 memory is divided in to two 32K ranges. The socket at U3 is placed within the range from \$0000 to \$7FFF while the socket at U4 is placed within the range of \$8000 to \$FFFF. Configuration jumpers JP7, JP12, JP13 and JP14 allow U3 to be configured for SRAM, EPROM or EEPROM. Likewise, JP8, JP9, JP10 and JP11 allow U4 to also be configured for SRAM, EPROM or EEPROM. While you can set the memory up as needed for your particular application, if you are setting up the default Retro Elf which includes the front panel, the schematic shows the default configuration with U3 as 32K SRAM and U4 as 32K or EEPROM.

Five-volt power regulation is provided by a simple analog voltage regulator circuit made up of D1, C5, U5 and C6. Power is presented via connector J3. The positive side is passed through the 1N4001 diode (D1). The 1N4001 helps prevent accidental reversals on the power supply input voltage. In normal operation the 1N4001 is forward biased allowing current to flow through. If the voltage becomes reversed, the diode will be reverse biased blocking current flowing in to the regulator circuits. The 220uF electrolytic capacitor in location C5 provided some DC input voltage ripple stabilization. The 7805

## Retro Elf Plus

regulator (U5) is used to regulate any input voltage between 8 and 12 volts DC down to a regulated 5 volts DC at up to one half an amp. The 7805 should be mounted to an appropriate heat sink when input voltage are at 12 volts DC and the optional front panel is installed. The 1uF capacitor (U6) is used to stabilize the final regulated output voltage of the 7805. Ten 0.1uF capacitors (C1, C2, C3, C4, C7, C12, C13, C14, C15 and C16) are used to help decouple IC generated power line noise on the 5-volt supply.

A power monitor LED is provided and is made up of LED D4 and the 1K ohm current limiting resistor R3.

The Retro Elf is setup to support simple software (bit-banging) serial. Driver hardware is provided to support the 1802's Q output line and one of the four jumper selectable EF input lines for this function. Two inverter stages in the 74HC04 (U6) are used for both the serial input and output to setup for normal or inverted signaling. Jumpers JP16 is used for serial out and JP17 is used for serial in. Voltage level conversion is supplied by a MAX232A (U7) and four 0.1uF capacitors (C8, C9, C10 and C11). The four capacitors allow the MAX232A to create a voltage pump and also a voltage inverter used to create the standard RS232 signal level on the serial lines present at J1. This allows for easy connection to most terminals or computer serial ports supporting RS232 signaling. The four jumper JP2 (EF4), JP3 (EF3), JP4 (EF2) and JP5 (EF1) are used to select which of the four 1802 EF lines will be used to monitor serial inputs. The 1N4148 switching diode (D5) is placed in line between the selected 1802 EF line and the serial input driver. This allows for a simple diode OR gate on the selected EF line allowing that line to be shared if needed.

Two LEDs are provided to monitor both the serial receive and send serial signals. LED D3 and 1K current limiting resistor R2 monitor the RXD (receive) signal while LED D2 and 1K current limiting resistor R1 are for TXD (send).

An ATF16V8B GAL (U12) is used to reduce logic chip count and provide flexibility for possible future design changes. In the current design, U12 support three functions.

The first operation supported by U12 is decode memory ranges for the chip selects on U3 and U4.

The second function is supporting the second half of the 74HC74 (U10) in creating a Bootstrap loader. After the -CLEAR signal is cycled, the Bootstrap disables U3 and places U4 in to the lower memory address between \$0000 and \$7FFFF. Depending of the setting of JP18, the Bootstrap state is cleared by setting the 1802's Q output line or performing any type of input/output operation. Jumper J1 can be used to disable the bootstrap process completely. Useful when the optional front panel is used. LED D6 and current 1K current limiting resistor R4 provide a bootstrap status indicator. The LED will be on while the bootstrap is enabled.

The final job of U12 is creating three process status outputs allowing the user to monitor what mode the 1802 is currently in. Each monitored channel is made up of an LED and a 1K current limiting resistor. RUN consists of D7 and R5, WAIT consists of D8 and R6 and finally RESET (aka CLEAR) consists of D9 and R7.

A 40-pin connector (J2) bring out most of the 1802's signals and also provides a source for 5 volts DC used by the front panel or any expansion cards.

## Retro Elf Plus

There is a special jumper labeled JP15 use to connect the 1802's MWR line to the SRAM. This jumper must be inserted any time the CPU board is not used with the optional front panel. If the front panel is used, JP15 must be removed since the front panel augments the MWR function.

A DS1210 (U11) is used to create a SRAM battery backup. If the DS1210 detects that the supply voltage drops below normal operation range, it will use the optional on board 3-volt battery (B1) to power socket U3. While U3 can support many types of SRAM, EPROM or EEPROM, to take advantage of the backup feature, a low current SRAM (like the AS6C62256) must be used to allow for a normal battery life.

## 4– Technical details

### J1 - RS232 Serial port pinout

The connector J1 is used as a simple RS-232-C interface for the CPU board. This connector conforms to the EIA (Electronic Industries Association) RS-232-C (August 1969) standards and should work with many terminal or computer serial interfaces that support this standard.

The RS-232-C standard defines the voltage levels that correspond to logical one and logical zero levels for the data transmission and the control signal lines. Valid signals are either in the range of +3 to +15 volts or the range –3 to –15 volts with respect to the Common Ground (GND) pin. The range between –3 to +3 volts is not a valid RS-232-C level.

The MAX232A serial interface integrated circuits used within the interface, fully supports RS-232-C serial input signals covering the complete range defined in the standard. The MAX232A drives the serial outputs levels of about +9 for a space (0) and –9 for a mark (1). These output signal levels again fall nicely within the RS-232-C standard.

Pin	Type	Label	Description
1	Input	RCV	RS232 serial data receive.
2	Input	DSR/CTS	Not Used by the CPU board.
3	Output	XMT	RS232 serial data transmit.
4	Output	DTR/RTS	Not Used by the CPU board.
5	Ground	Ground	Common ground.

## Retro Elf Plus

### J2 – Retro Elf Bus

Pin	Type	Label	Description
1	Power	+5VDC	Regulated positive five volt power supply.
2	Power	+5VDC	Regulated positive five volt power supply.
3	BiDir	D0	Main system data bus bit 0.
4	BiDir	D1	Main system data bus bit 1.
5	BiDir	D2	Main system data bus bit 2.
6	BiDir	D3	Main system data bus bit 3.
7	BiDir	D4	Main system data bus bit 4.
8	BiDir	D5	Main system data bus bit 5.
9	BiDir	D6	Main system data bus bit 6.
10	BiDir	D7	Main system data bus bit 7.
11	Output	MA0	Memory Address line 0 for bits 0 or 8.
12	Output	MA1	Memory Address line 1 for bits 0 or 9.
13	Output	MA2	Memory Address line 2 for bits 0 or 10.
14	Output	MA3	Memory Address line 3 for bits 0 or 11.
15	Output	MA4	Memory Address line 4 for bits 0 or 12.
16	Output	MA5	Memory Address line 5 for bits 0 or 13.
17	Output	MA6	Memory Address line 6 for bits 0 or 14.
18	Output	MA7	Memory Address line 7 for bits 0 or 15.
19	Output	CLEAR	Main system CLEAR (aka RESET) signal.
20	Output	WAIT	Main system processor WAIT (HALT) signal.
21	Input	DMA IN	Direct Memory Access Input.
22	Output	DMA OUT	Direct Memory Access Output.
23	Output	N0	Input / output select line 0.
24	Output	N1	Input / output select line 1.
25	Output	N2	Input / output select line 2.
26	Output	TPA	Timing Pulse A.
27	Output	TPB	Timing Pulse B.
28	Output	CLOCK	Main system Clock.
29	Output	-MRD	Memory Read signal.
30	Output	-WE	Memory Write Enable.
31	Output	-MWR	Memory Write signal.
32	Output	SC0	
33	Output	SC1	
34	Input	INT	Main system Interrupt.
35	Output	Q	Processor Q line output.
36	Input	EF1	Processor External Flag One input.
37	Input	EF2	Processor External Flag Two input.
38	Input	EF3	Processor External Flag Three input.
39	Ground	GND	System Ground.
40	Ground	GND	System Ground.

## Retro Elf Plus

### J3 – CPU board power

Pin	Type	Label	Description
<b>1</b>	Power	+V	Main expansion board power supply +8 to 16VDC at 1A maxum.
<b>2</b>	Ground	Ground	Power ground.



Appendix A - CPU board schematics

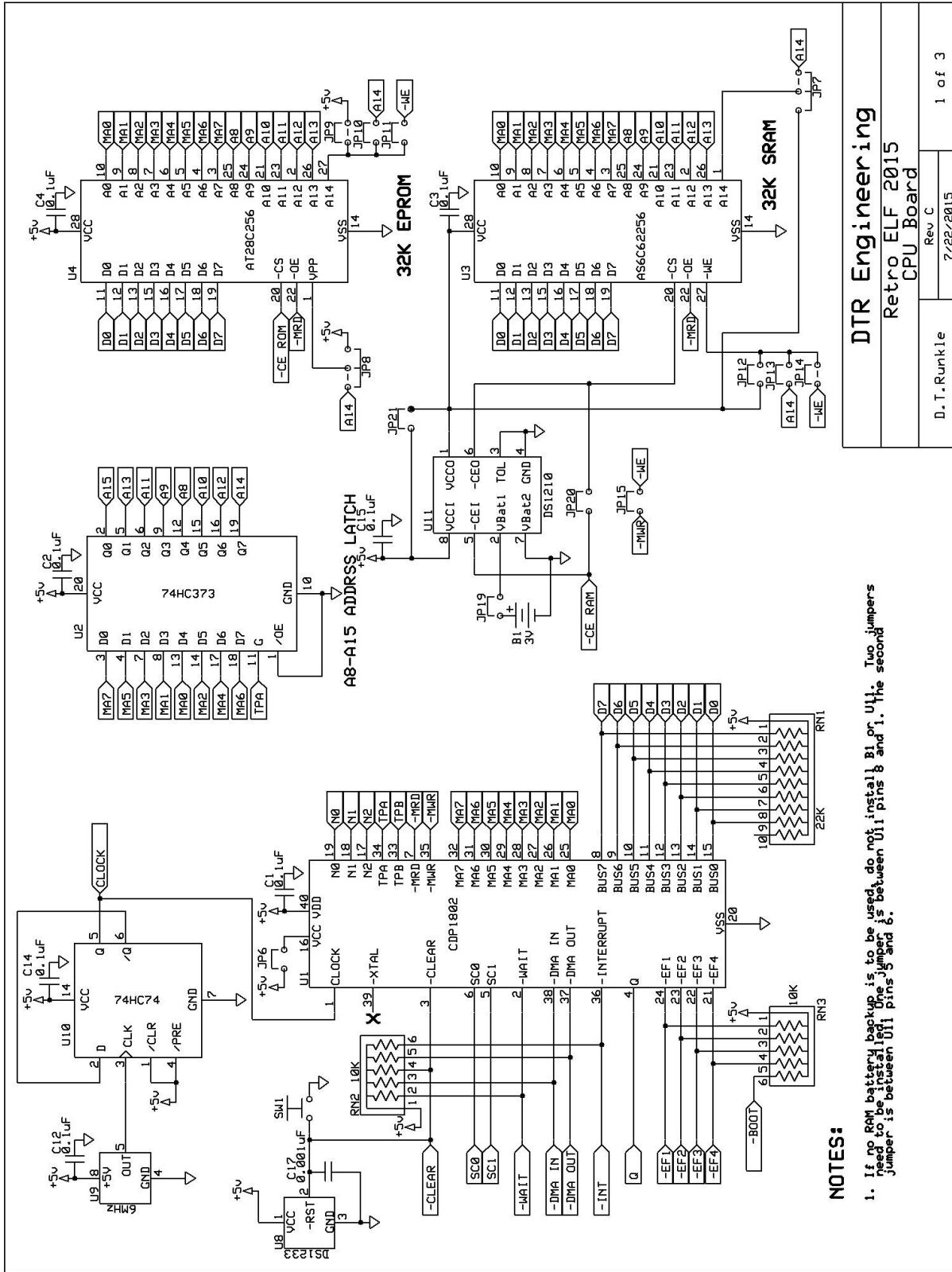

DTR Engineering  
Retro ELF 2015  
CPU Board

D. T. Runkle  
Rev C  
7/22/2015  
1 of 3

**NOTES:**  
1. If no RAM battery backup is to be used, do not install B1 or U11. Two jumpers need to be installed. One jumper is between U11 pins B and I. The second jumper is between U11 pins S and 6.

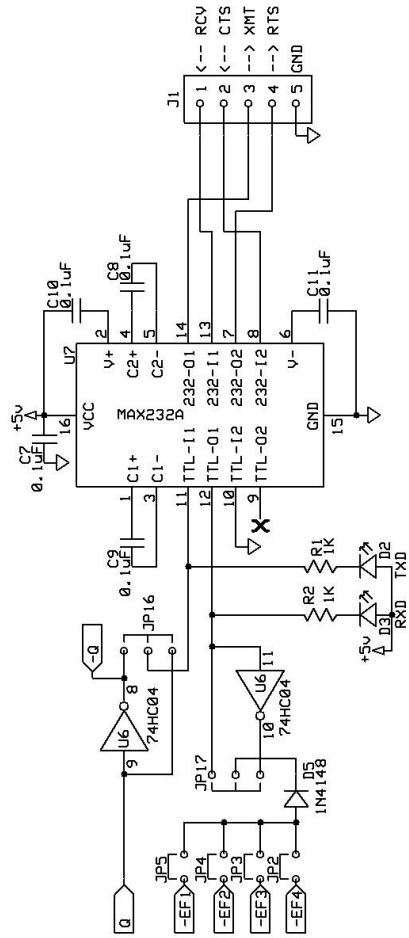
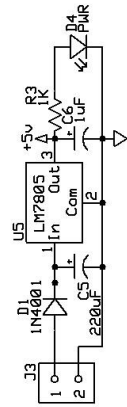

<b>DTR Engineering</b>	
Retro ELF 2015 CPU Board	
D. T. Runkle	Rev C 7/22/2015
2 of 3	

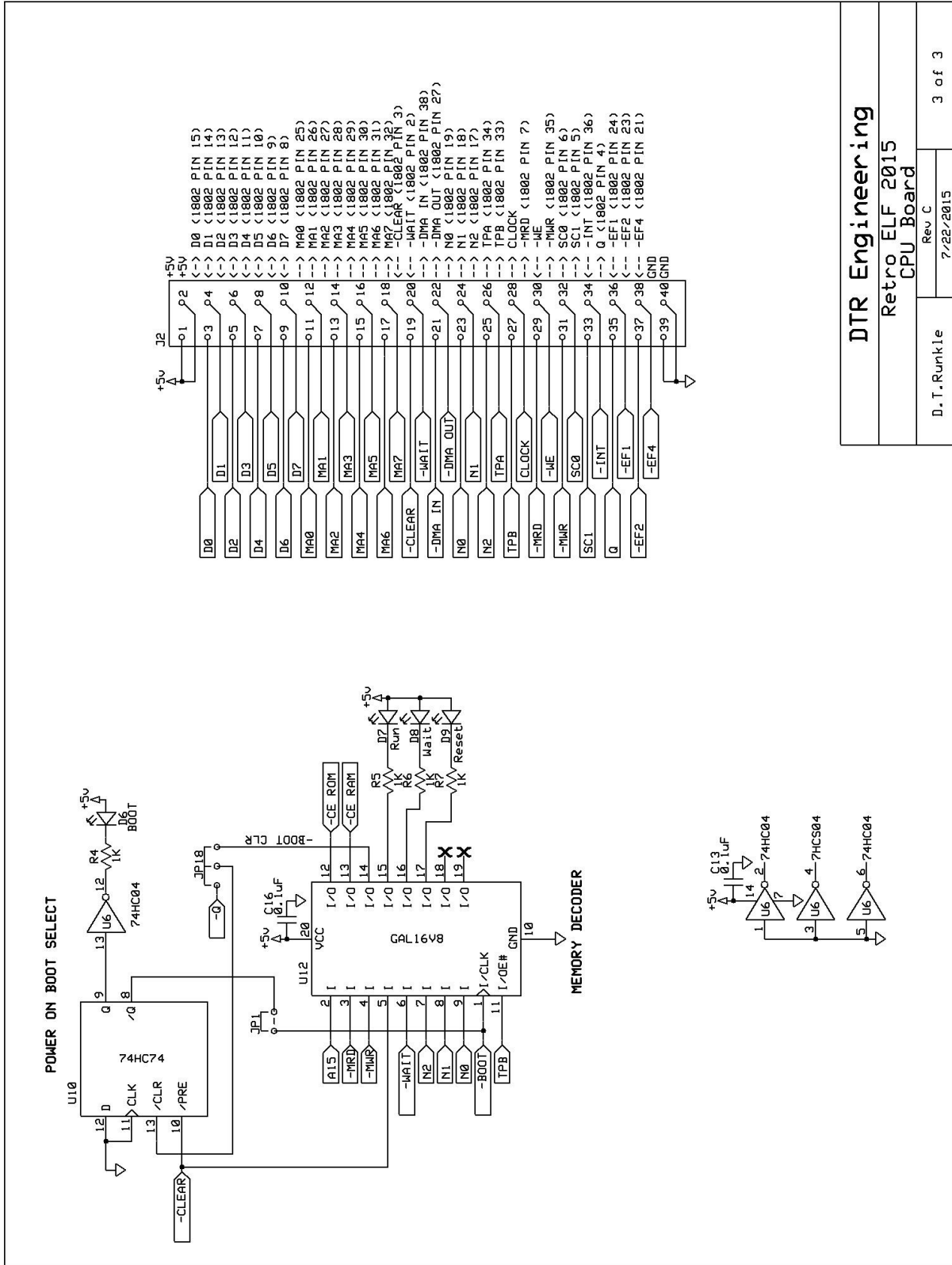

<b>DTR Engineering</b>	
Retro ELF 2015 CPU Board	
D. T. Runkle	Rev C 7/22/2015
3 of 3	

## Retro Elf Plus

### Appendix B – CPU board parts list

Location	Qty	Description	Vendor	Vendor PN	MFG	MFG PN
B1	1	Battery Lithium 12.5MM Coin PC Pins	Digi-Key	P191-ND	Panasonic	BR-1225
C1, C2, C3, C4, C7, C8, C9, C10, C11, C12, C13, C14, C15, C16	14	Capacitor CER 0.1uF 50V 20% Radial	Digi-Key	399-4151-ND	Kemet	C315C104M5U5TA
C17	1	Capacitor ceramic 1000pF 50V 20% Radial	Digi-Key	399-3770-ND	Kemet	C320C102M5R5TA
C5	1	Capacitor alum 220uF 20% 16V axial	Digi-Key	TVX1C221MAD-ND	Nichicon	TVX1C221MAD
C6	1	Capacitor 1uF Tantalum	Digi-Key	399-3533-ND	Kemet	T350A155K025AT
D1	1	Diode 1N4001 General Purpose 50V 1A DO41	Digi-Key	1N4001GOS-ND	ON Semiconductor	1N4001G
D2,D3,D9	3	1 ¼ Red LED	Digi-Key	754-1266-ND	Kingbright	WP7113UD
D4,D7	2	1 ¼ Green LED	Digi-Key	754-1265-ND	Kingbright	WP7113GD
D6,D8	2	1 ¼ Yellow LED	Digi-Key	754-1268-ND	Kingbright	WP7113YD
D5	1	Diode 1N4148	Digi-Key	1N4148TACT-ND	Fairchild	1N4148TA
J1	1	Connector header 5 position 0.1 pitch vertical tin	Digi-Key	WM4203-ND	Molex Inc	22232051
J2	1	Header 40 pin 2 x 20, 0.1 pitch	Digi-Key	WM8134-ND	Molex Inc	901310140
J3	1	Connector header 2 position 0.1 pitch vertical tin	Digi-Key	WM4200-ND	Molex Inc	22232021
JP1, JP2, JP3, JP4, JP5, JP6, JP7, JP8, JP9, JP10, JP11, JP12, JP13, JP14, JP15, JP16, JP17, JP18, JP19, JP20, JP21	21	JUMPER SKT BLACK	Digi-Key	952-2165-ND	Harwin Inc	M7567-46
JP1, JP2, JP3, JP4, JP5, JP6, JP9, JP10, JP11, JP12, JP13, JP14, JP15, JP19, JP20, JP21	16	2-Pin	Digi-Key	3M9447-ND	3M	961102-6404-AR
JP7, JP8, JP16, JP17, JP18	5	3-Pin	Digi-Key	3M9448-ND	3M	961103-6404-AR
R1, R2, R3, R4, R5, R6, R7	7	Resistor 1Kohm 1/8-watt 5% CF axial	Digi-Key	CF18JT1K00CT-ND	Stackpole	CF18JT1K00
RN1	1	Resistor Network 22K x 9 SIP- 10	Digi-Key	4610X-1-223LF-ND	Bourns Inc	4610X-101-223LF
RN2, RN3	2	Resistor Network 10K x 5 SIP-6	Digi-Key	4606X-1-103LF-ND	Bourns Inc	4606X-101-103LF
SW1	1	Switch tactile SPST-NO	Digi-Key	SW405-ND	Omron Electronics	B3F-1052
U1	1	Socket IC 40 Pin	Digi-Key	AE10018-ND	Assmann WSW	AR-40-HZL-TT
U2, U12	2	Socket IC 20 Pin	Digi-Key	AE10015-ND	Assmann WSW	AR-20-HZL-TT
U3, U4	2	Socket IC 28 Pin	Digi-Key	AE10017-ND	Assmann WSW	AR-28-HZL-TT
U6, U10	2	Socket IC 14 Pin	Digi-Key	AE10012-ND	Assmann WSW	AR-14HZL-TT
U7	1	Socket IC 16 Pin	Digi-Key	AE10013-ND	Assmann WSW	AR16-HZL-TT
U9, U11	2	Socket IC 8 Pin	Digi-Key	AE10011-ND	Assmann WSW	AR-08-HZL-TT
U1	1	CDP1802ACE - 8 Bit CMOS Microprocessor	Digi-Key		Harris	CDP1802ACE
U2	1	74HC373 - IC OCT TRANSP D LATCH 20-DIP D	Digi-Key	296-1591-5-ND	Texas Instruments	SN74HC373N
U3	1	62256 - SRAM 32K x 8	Digi-Key	1450-1033-ND	Alliance Memory Inc	AS6C62256-55PCN
U4	1	28C256 - EEPROM 32K x 8 (Programmed)	Digi-Key	AT28C256-15PU-ND	Atmel	AT28C256-15PU
U5	1	LM7805 - +5 Volt Regulator	Digi-Key	MC7805CT-BPMS-ND	Micro Commercial Co	MC7805CT-BP

## Retro Elf Plus

U6	1	74HC04 - IC HEX INVERTER 14-DIP	Digi-Key	296-1566-5-ND	Texas Instruments	SN74HC04N
U7	1	MAX232A - IC	Digi-Key	MAX232ACPE+-ND	Maxim Intergraded	MAX232ACPE+
U8	1	DS1233 - IC ECONORESET 5V 10% TO92-3	Digi-Key	DS1233-10+-ND	Maxim Intergraded	DS1233-10+
U9	1	OSC XO 4.000MHZ HCMOS TTL PC PIN	Digi-Key	X202-ND	ECS Inc	ECS-2100A-040
U10	1	74HC74 - IC	Digi-Key	296-1602-5-ND	Texas Instruments	SN74HC74N
U11	1	DS1210 - IC CONTROLLER CHIP NV 8-DIP	Digi-Key	DS1210+-ND	Maxim Intergraded	DS1210+
U12	1	GAL16V8 "Retro ELF CPU Ver:C"	Digi-Key	ATF16V8B-15PU-ND	Atmel	ATF16V8B-15PU
U5	1	Heatsink TO-220	Digi-Key	HS107-ND	Aavid Thermolloy	577202B00000G
U5	1	Machine Screw Pan Philips M3x7	Digi-Key	335-1149-ND	APM Hexseal	RM3X8MM 2701
U5	1	Hex Nut M3	Digi-Key	H762-ND	B&F Fastener Supply	MHNZ 003

Appendix C – Printed circuit board parts locations

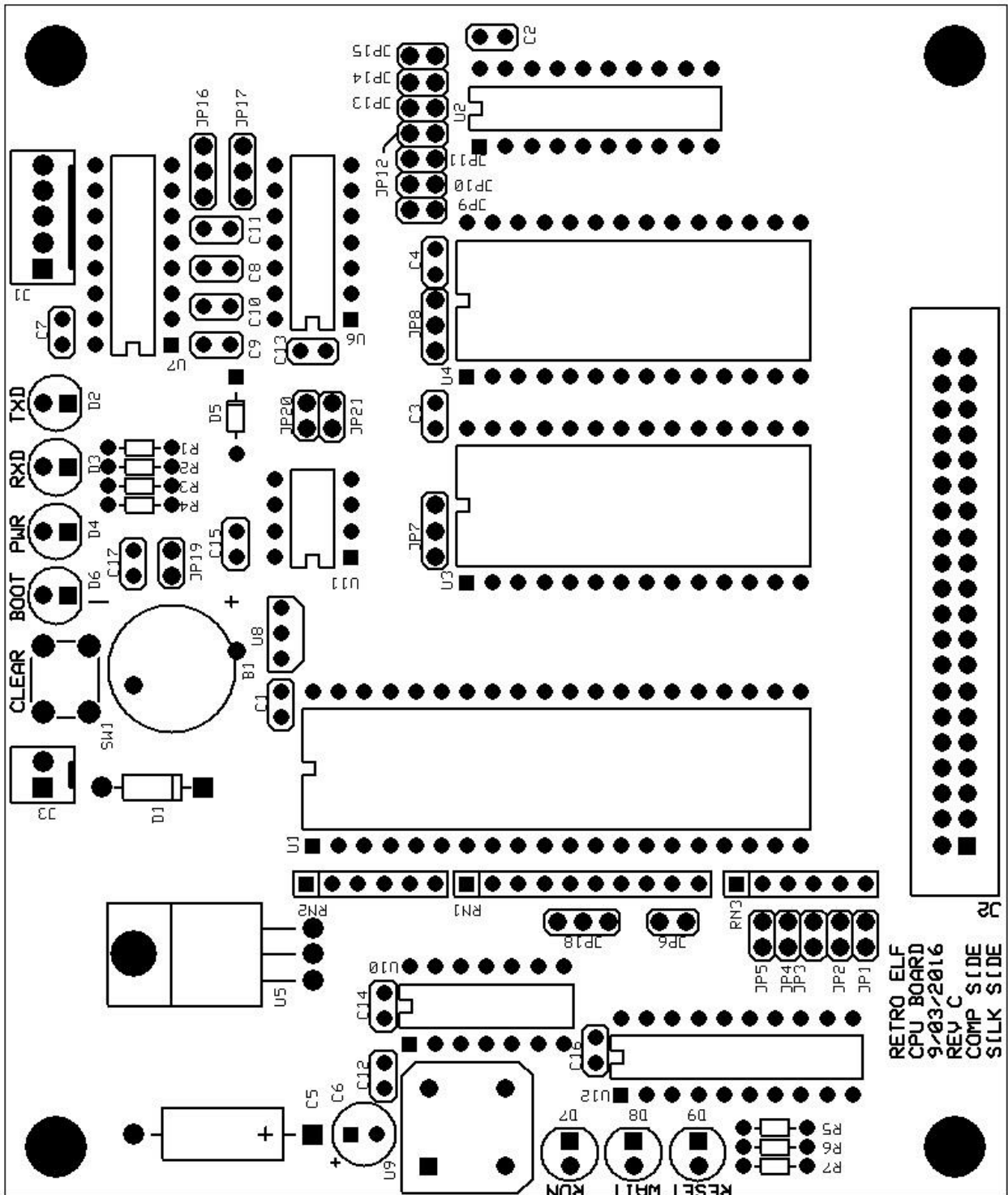

Appendix D – Connectors and jumpers

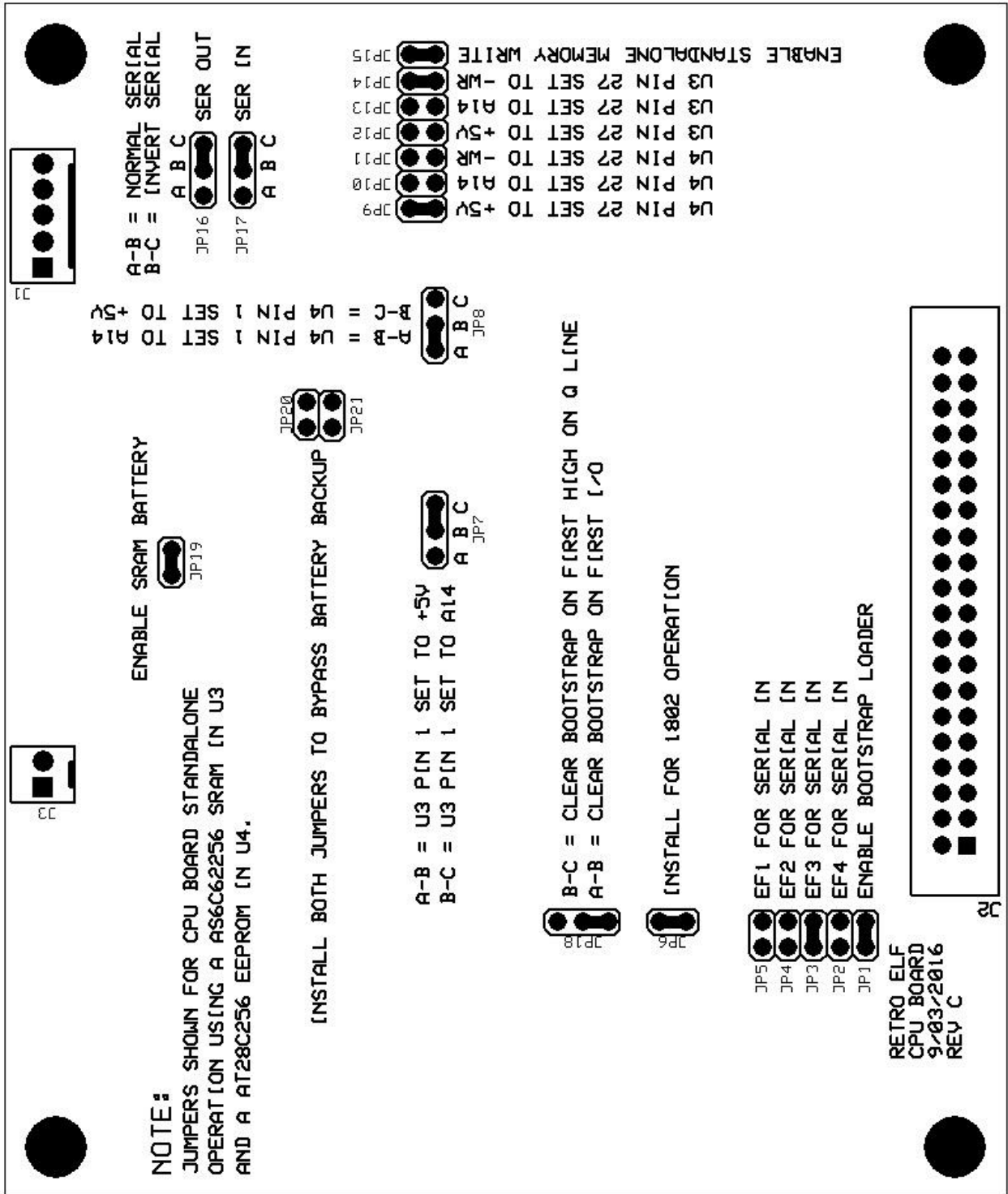

## Appendix E – V88 Spare Time Gizmos Firmware

The Retro Elf design, it will work with the V88 hex image of the Spare Time Gizmos software. Not all the features found within the hex image will work on the Retro Elf. Refer to the following list for unsupported feature:

CLS  
SEdit  
SET  
NVR  
DEFAULT  
SHOW CPU  
SHOW DATIME  
SHOW RTC  
TEST UT1802  
TEST PIXIE

### Setup using a standalone CPU or CPU/Front Panel combo

The following steps should setup the Retro Elf to support V88:

1. Go to the Spare Time Gizmos web site and download the V88 hex file.
2. Use the file to burn (create) the hex image in to some version of 32K EPROM /EEPROM.
3. Strap jumper JP6 to use a standard CDP1802 variant microprocessor.
4. Install a 32K SRAM at location U3 and set jumper JP7, JP13, JP14 and JP15 to support.
5. Install the EPROM/EEPROM at location U4 and set jumpers JP8, JP9, JP10 and JP11 to support.
6. If you are using a standalone CPU Board, enable Bootstrap loader by strapping JP1. Otherwise remove.
7. Set serial input to use EF3 by strapping JP3.
8. If you are using a standalone CPU Board, enable memory writing by strapping JP15. Otherwise remove.
9. Set the serial output for inverted serial output by strapping jumper JP16 B-C.
10. Set the serial input for inverted serial input by strapping jumper JP17 B-C.
11. Set Bootstrap to clear on first I/O by strapping jumper JP18 A-B.

If you are using a standalone CPU board, power cycling or pressing the clear (reset) button will bring the bootstrap loader in to play. There will be up to a ten second delay for the POST (Power-On Self-Test) to complete before pressing the enter or space key on a terminal device will generate a reply from the Elf.

When the optional Front Panel is used, normally the Bootstrap is disabled. After a power up or clear, you will most likely need to use the toggle switches to write a long branch (C3 80 00) in to the first three bytes of RAM. Then clear and run. The system will run the long-branch at the beginning of RAM and jump to the beginning of the V88 code at \$8000. The system will again go through the POST process but this time the data LEDs on the Front Panel should be changing to display each of the POST codes. Go to the Spare Time Gizmos website for a listing of the POST codes found in the Elf2K documentation. Press enter (echo characters) or space key (do not echo characters) on a terminal device to generate a reply from the Elf.



## Retro Elf Plus